

Gulf English School

مدرسة الخليج الإنجليزية



Emergency Evacuation Policy

Created by:

Paul Luijting

Reviewed by:

Israr Shah - Paul Luijting

Updated:

April 2025

In to effect

Sept.'26

CONTENTS

	Page
1 Introduction	3
1.1 Purpose	3
1.2 Aim	3
2 Responsibility During Evacuation	4
2.1 Class Teacher / Form Tutor	4
2.2 Specialist Staff	4
2.3 Primary Music and PE Teachers	5
2.4 Year coordinator / Year Leader	5
2.5 Head of Department	5
2.6 Administrative Staff	6
2.7 Support Staff	6
2.8 Security Staff	7
2.9 Deputy Headteacher	7
2.10 Principal	7
3 Accounting	8
3.1 Accounting for Students	8
3.2 Accounting for Visitors	8
3.3 Accounting for Primary Students in Secondary Basement	8
4 General Considerations	9
4.1 Evacuation Assembly Area Considerations	9
4.2 Scheduled Evacuation Drills	9
4.3 Evacuation during Break Times	10
4.4 Evacuation of Primary Students in Secondary Basement	10
5 Event Specific Considerations	11
5.1 Fire Equipment and Prevention	11
5.2 Evacuation during External Examination	11
5.3 Siege / Hostage	11
5.4 Bomb Threat	12
5.5 Toxic Emissions	12
5.6 Earthquake	12
5.7 Civil Defense Sirens	12
6 Appendix	14



1. INTRODUCTION

1.1 Purpose

The procedures within contain information necessary to allow a quick and effective evacuation of the buildings when the need arises.

If the need arises for an emergency evacuation of the school, through a fire or some other cause, all school personnel must be fully aware of the correct procedures to minimize the risk of danger or injury. Teaching staff are required to read the detailed policy on this matter and explain in full to students the evacuation procedures

The purpose of this plan is to minimise the impact of crises on students, teachers, support staff, parents and visitors in the event of an emergency. It aims to deal with the school's response to all forms of emergency in which evacuation is required. The Senior Leadership Team (SLT) will review this policy annually with advice being requested from staff and students.

1.2 Aim

This policy aims to enable:

- Evacuation of all students, staff, parents and visitors in an organized and controlled movement from a threatened danger area to a safe area,
- Evacuate everyone from school building to the safe area in the minimum possible time,
- Ensure that exposure to danger and the possible risk of injury are minimised.

Within these aims it is hoped that this policy provides support in effecting evacuation of the school buildings in a manner which:

- prevents harm to staff and students of Gulf English School,
- minimises damage and loss to school property,
- minimises destruction to students' property,
- minimises panic, fright and trauma to staff and students,
- is safe, quick and efficient,

2. RESPONSIBILITY DURING EVACUATION

2.1 Class Teacher / Form Tutor

Teachers in classrooms are to instruct their students to evacuate to the Emergency Evacuation Assembly Area. It is the teacher's responsibility to ensure the following procedure takes place (If a 'cover' Teacher is in the classroom, the teacher next door will notify them of the procedure):

- Students cease work immediately
- Students and staff to leave all books (with exception of registers), practical work and bags
- Teacher to direct students as to the correct evacuation route.
- At the direction of the teacher, students are to stand and move out of the room in a controlled and quiet manner.
- Upon the students leaving the classroom, the lights are to be turned off, windows closed, accessible electrical equipment is to be turned off and the door closed (not locked).
- As each class reaches the Emergency Evacuation Assembly Area, the students are to assemble in line under the direct supervision of their Class (Primary) or Form (Secondary) teacher.
- Class (Primary) or Form (Secondary) Teachers will mark their class register. The Year coordinator / Year Leader should be informed as quickly as possible if all students are present or the details if any are missing.
- The names of students missing, must be given to the Year coordinator
- Students are to remain lined up until permission is given to either reenter the building (directed by SLT) or alternate instructions are given (by SLT).

If a primary class has a lesson in the basement (Music or PE) the class teacher should be aware of this and ensure that if needed they are available at the "Visitors & PE/Music Basement (Primary)" Evacuation area in order to account for students.

2.2 Specialist Staff

Teachers in classrooms are to instruct their students to evacuate to the Emergency Evacuation Assembly Area. It is the teachers responsibility to ensure the following procedure takes place (If a 'cover' Teacher is in the classroom, the teacher next door will notify them of the procedure):

- Students cease work immediately
- Students and staff to leave all books (with exception of registers), practical work and bags
- Teacher to direct students as to the correct evacuation route.
- At the direction of the teacher, students are to stand and move out of the room in a controlled and quiet manner.

- Upon the students leaving the classroom, the lights are to be turned off, windows closed, accessible electrical equipment is to be turned off and the door closed (not locked).

Upon reaching the Evacuation Assembly Point, Specialist staff should ensure that they act to support Class (Primary) and Form (Secondary) teachers in ensuring students are lined up correctly, and remain calm and quiet.

Non-teaching Music and PE staff may assemble at the area identified on the Evacuation and Assembly overview so that they can be assigned additional responsibility if needed.

2.3 Primary Music and PE Teachers

Teachers of Primary Music and PE with classes in the basement should follow the standard procedures for class teachers, evacuating as normal. Upon exiting the building students should be directed to gates 1 and 3 and assembled in the “*Visitors & PE/Music Basement (Primary)*” Evacuation Assembly Area. A member of reception staff will be assigned to act as ‘coordinator’ between these classes and the relevant Deputy Headteachers to ensure that information on missing students is passed along the correct line of communication.

2.4 Year Coordinator

Upon reaching the Evacuation Assembly Point Head of Year (Secondary) and Year Leader (Primary) are required to assist in organizing their year groups classes. As quickly as possible they should identify with the class (Primary) teacher or form (Secondary) tutor which classes are present in full, which may have students missing and the identities of those students. This information should then be passed immediately to the relevant Deputy Headteacher.

Year coordinator (Secondary) and Year Leader (Primary) should wait ensure all staff and students remain in the Evacuation Assembly area until such time as a member of SLT informs them that it is safe to return to the building or the details of alternative arrangements.

2.5 Head of Department

Heads of Department (HOD) should ensure that they support the evacuation of students from the school. Those with assigned positions on the secondary evacuation route should guide students and ensure that risk is minimized as the students are moving from the school site to the Emergency Evacuation Assembly points. All other HODs should provide support during the evacuation and as needed at the Assembly Points.

2.6 Administrative Staff

When an Evacuation of the building is required administrative staff are expected to fulfill a number of roles:

- Secretaries are to immediately collect registers that are in the school office(s) and deliver them to the relevant assembly points. This should be carried out as quickly as possible.
- The allocated reception staff should act as “Visitor Link” collect visitors logs and assemble at the visitor assembly point to ensure all visitors are accounted for. This information should be passed to the Administrative Supervisor
- The allocated reception staff should act as “Reception – Primary Link”, gathering information from those classes who evacuated to the “Visitors & Primary from Secondary Basement” and passing details of full classes and students unaccounted for to the relevant Deputy Headteacher.
- Administrative supervisor should coordinate with the Principal regarding the evacuation, any alarms that have been sounded and the processes underway. They should coordinate with reception staff on accounting for visitors.

2.7 Support Staff

Teaching Assistants should act to support teaching staff during the evacuation. They should ensure that students leave classrooms in an orderly quiet fashion and move safely to the Emergency Evacuation Assembly area. Once at the Assembly area, teaching assistants should support teaching staff in ensuring students are arranged correctly and remain calm and quiet.

Laboratory Technicians should ensure that, if possible, possible gas is turned off and materials in science prep rooms are left in a safe state. They should ensure that chemicals are left secured. On evacuating the building they should assemble in the “Visitors & Primary from Secondary Basement” and communicate with the Administration supervisor if they have any information relating to the evacuation.

Librarians should evacuate any students not under direct supervision of a class teacher. If a class is using the library; the librarian is to assist in the evacuation of that class.

Nurses should evacuate those students in the nurses’ room(s) to the “Visitors & Primary from Secondary Basement” evacuation point. They should then inform the “Reception – Primary Link” so that these students can be accounted for.

2.8 Security Staff

Security staff are to ensure that all staff, students and visitors have evacuated the building and that the building is secure (no doors should be locked) in preparation of the arrival of emergency services.

2.9 Deputy Headteacher

Deputy Headteachers should ensure the evacuation is carried out quickly and calmly. On arriving at the Evacuation Assembly Point in Salmiya park they are to act as the point of contact for the relevant Year leaders and Heads of Year. They are required to pass on information pertaining to missing students to the Principal as it becomes available along with the accountability assessment of their relevant year groups.

2.10 Headteacher Secondary & Headteacher Primary

The Headteachers will act to monitor the evacuation of the building and the assembly at the Assembly points in Salmiya Park.

Should the Principal be absent, they will act in their place. Should a Deputy Headteacher be absent they will act in their place. If a Deputy Headteacher requires assistance due to staff absence in Year Leaders or Heads of Year, the Headteacher will undertake the Deputy Headteachers role as required.

2.11 Head Teacher

Unless otherwise informed that a drill is taking place, the Principal will on hearing the alarm immediately contact the police / fire brigade on the emergency number.

The Principal should assemble at the SLT assembly point as detailed on the Evacuation and Assembly Overview. They are to act as the main point of communication with emergency services, Head office, and will be provided with information through the Administrative Supervisor, Headteachers and Deputy Headteachers.

The Principal will notify all known missing students, staff and visitors to the police / fire brigade.

3. ACCOUNTING

The Principal will notify all known missing students, staff and visitors to the police / fire brigade.

3.1 Accounting for Students

Upon assembly of a class at the Evacuation Assembly Point, it is the responsibility of the Class teacher (Primary) or Form tutor (Secondary) to identify if any students are missing. This process should involve the use of the Yellow paper registers. These teachers should then inform the relevant Year Leader (Primary) or Year coordinator (Secondary) whether their class has any missing students or is fully accounted for.

Once informed, it is the responsibility of the Year Leader (Primary) or Head of Year (Secondary) to inform the relevant Deputy Headteacher as to which classes are fully accounted for, Which have missing students, what the identity of those missing students is. The deputy Headteachers will then pass this information for their key stage to the Principal.

3.2 Accounting for Visitors

Visitors should be assembled in the “Visitors & Primary from Secondary Basement” as detailed on the Evacuation and Assembly Overview. It is the responsibility of reception staff to collect the visitor log before exiting the building and to account for the visitors on that log. Those unaccounted for should be passed to the Administrative supervisor who will pass the information to the Principal.

3.3 Accounting for Primary students in Secondary Basement

Should an evacuation be required while primary students are in the secondary basement (Music and PE classes) they will assemble in the “Visitors & Primary from Secondary Basement” in place of the usual area in Salmiya Park. The specialist teacher is responsible for ensuring that all students are assembled in that location. The specialist teacher should then communicate this information to the allocated reception staff who is acting as “Reception – Primary Link”. The “Reception – Primary Link” will then pass details of full classes and students unaccounted for to the relevant Deputy Headteacher using the most suitable communication media.

4. GENERAL CONSIDERATIONS

- Regular inspection and maintenance of installed fire protection equipment must be undertaken.
- The priority for staff is the evacuation and supervision of students. Staff are not to engage in any firefighting operations until the evacuation is complete and ONLY if trained to use the equipment.
- Students are never to be utilized in any fire-fighting activities.
- Emergency Evacuation maps are to be displayed prominently in every classroom and workplace in the school.
- At the beginning of each year (and when different at the beginning of each new staff members contract), the emergency evacuation policy should be explained and demonstrated
- Class (Primary) and Form (Secondary) teachers should be providing a full description and expectations of the process to students. It must be impressed upon students, of the seriousness of conducting emergency evacuation drills. The expectations of student behaviour during these drills will be very high.

4.1 Evacuation Assembly Area Considerations

- All persons missing during an evacuation will be reported to the Fire Brigade/Police via the Principal. Staff will take instruction from the Emergency Services with regard to missing students and/or staff. No person is to attempt to re-enter the school premises to search for missing people.
- Staff are to assist emergency Services personnel on request.
- Students are to be carefully and closely supervised at all times.
- No-one is to leave the Emergency Evacuation Assembly area without first gaining permission from the Principal (via SLT)
- No-one is to return to the school site without the ALL CLEAR being given by the Emergency Services and communicated by the Principal (via SLT).

4.2 Scheduled Evacuation Drills

- A minimum of three evacuation drills should be scheduled each school year, with one in Terms 1 and 2.
- Two of the drills should be conducted with full prior notice to staff, while the other drill will be conducted with partial notice to Senior staff (Full Prior notice includes: term, week, day, time)
- An evacuation drill with partial notice will be initiated by the Director.

- Different scenarios will need to be created to deliberately alter the behaviour of staff and students.
- The Emergency Evacuation routes could be deliberately blocked so that alternative routes would need to be used.
- The means of entry to the Emergency Evacuation Assembly Area could also be deliberately blocked so that alternative routes would need to be found.
- Feedback after each evacuation drill will be collected in an effort to gain feedback and to establish the degree of success of the drill and highlight areas to improve.

4.3 Evacuation During Break Time

In the event that the alarm is sounded during break times, all teachers will move to the playground areas and assist staff on duty to move students. Students will be evacuated to the nearest school gate allocated to their age group.

4.4 Evacuation of Primary Students in Secondary Basement

Primary students may be in the secondary part of the school basement during Music and PE lessons. These students should follow the standard evacuation route with their class teacher, but should leave the site through Gate 1 or Gate 3. To avoid difficulties, which may be posed by primary students travelling the secondary student route to the emergency evacuation assembly points in Salmiya Park, these Primary classes should instead assemble in the Visitors section in front of Gate 2.

Primary class teachers whose class are evacuated in this way should make their way to this location to ensure all students are accounted for. In this case a member of Reception will be allocated to pass this pupil accounting information directly to the relevant Deputy Head in place of the usual Year Leader.

5. EVENT SPECIFIC CONSIDERATIONS

5.1 Fire Equipment and Fire Prevention

- Fire extinguishers will be checked as per local regulations.
- Combustible and flammable materials are NOT to be placed on or near heating appliances.
- The use of double adaptors is to be avoided. Two or more double adaptors must NEVER be used at the same power point.
- In an electrical storm, appliances including T.V. and computers should be turned off at the wall.
- If an evacuation is called, assessable electrical items should be turned off.
- Each section of the building has a red fire cupboard, containing a hose reel capable of reaching all areas of that section, along with portable water and powder fire extinguishers for use on smaller fires. Powder fire extinguishers should be used when the source of fire is unclear.
- Fire Blankets and Carbon Dioxide fire extinguishers are to be found in science laboratories
- Nurses room and Canteen contain fire blankets.

5.2 Evacuation During External Examinations

See Head of Centre Exam office

5.3 Siege / Hostage

1. Confirm available facts by personal observation or by a second information source.
2. Contact the police.
3. Evacuate-partially or totally.
4. Lock In (Unable to evacuate). Words "Lock In" said.
Head/Deputy/Secretary to notify all class Teachers to
Close doors / windows / blinds / secure children out of sight and
Keep children quietly calm.
Teachers await further instructions from SLT
Principal to contact Emergency Services and Head office
5. Assemble personnel with a direct knowledge of:
 - Events
 - Interior layout / topography
 - The hostage/s or
 - The assailants.
6. Co-operate and assist police as necessary.



5.4 Bomb Threat

1. Principal to call the police.
2. Evacuate as per exit procedures.
3. Principal to notify the Head Office.

5.5 Toxic Emissions

(Gas, Fuels or chemicals, which may cause risk to health)

1. When alerted, check the source of the disaster.
2. Close all windows and doors.
 - If the source is external, retain students within the school.
 - If source is identified as internal, evacuation procedure should be followed
3. Call the police.
4. The principal awaits instructions from the Officer-In-Charge.
5. Principal to notify the Head Office.

5.6 Earthquake

Indoors

1. Get everybody under desks and tables or a door frame.
2. Ensure nobody leaves the building.
1. When tremor has subsided:
 2. Evacuate everybody clear of buildings, trees and power lines
 3. Tune into the radio and follow any emergency instructions.
 4. SLT to inform before allowing students to re-enter.

Outdoors

1. Move everybody away from buildings, trees and power lines.
2. Tune into the radio and follow emergency instructions.
3. SLT to inform before allowing students to re-enter

5.7 Kuwait Civil Defense Sirens

Types of sound:

- A single tone which is not continuous indicates possible danger.
- A wave sound indicates something that has already happened.
- A continuous tone means that danger is over.

1. Get everybody under desks and tables or a door frame.
2. Ensure nobody leaves the building.
3. Wait for instructions from SLT or Civil Defence operatives.

6 . APPENDIX

Appendix i

- Evacuation and Assembly Overview
- Site Exit Overview
- Secondary Assembly Points – Salmiya Park

Appendix ii

- Evacuation Route

Appendix iii

- Emergency Evacuation – Your Role

Appendix iv

- Emergency Evacuation - Reporting Structure

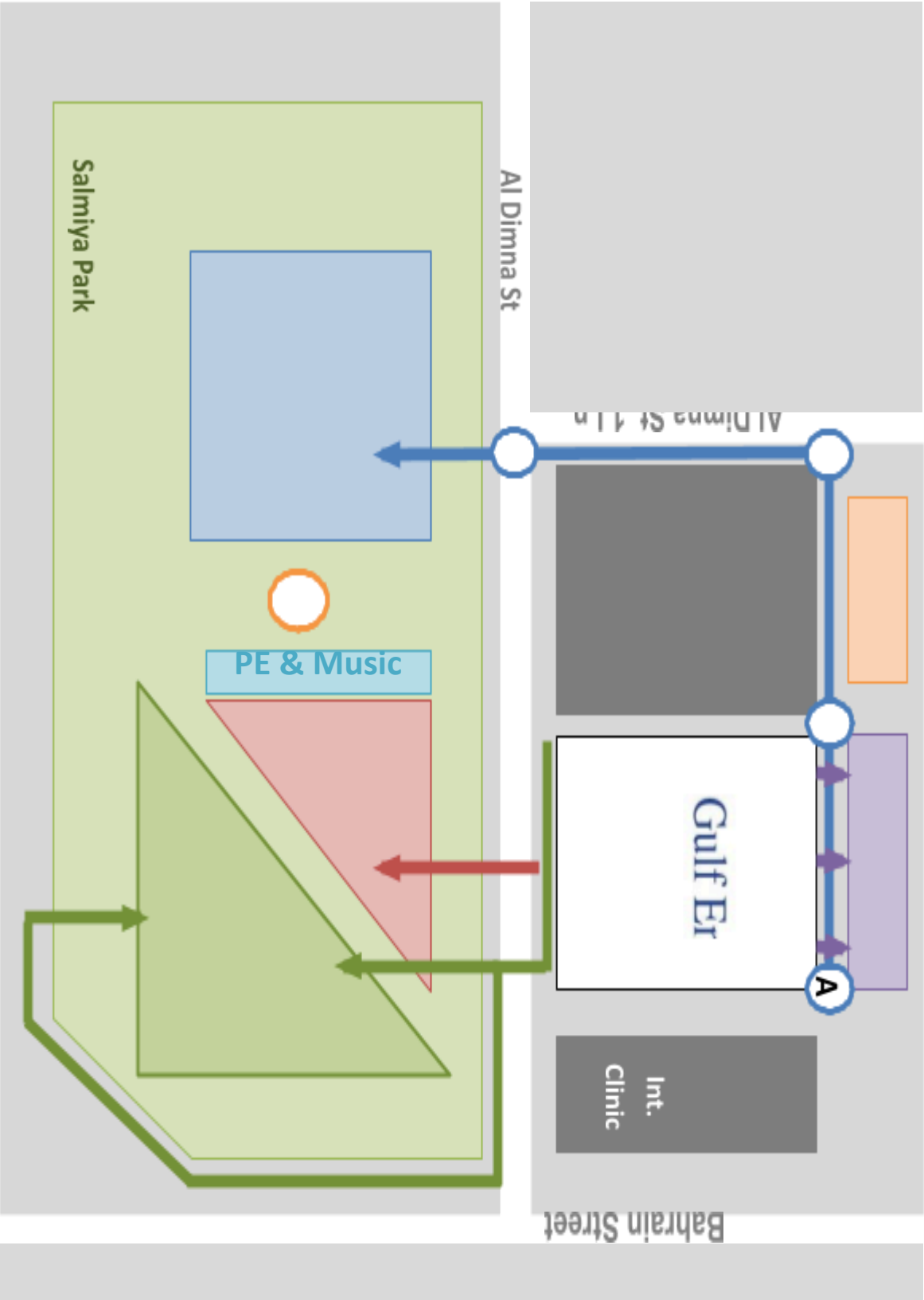

Appendix v

- Details - Key Roles – Contact details

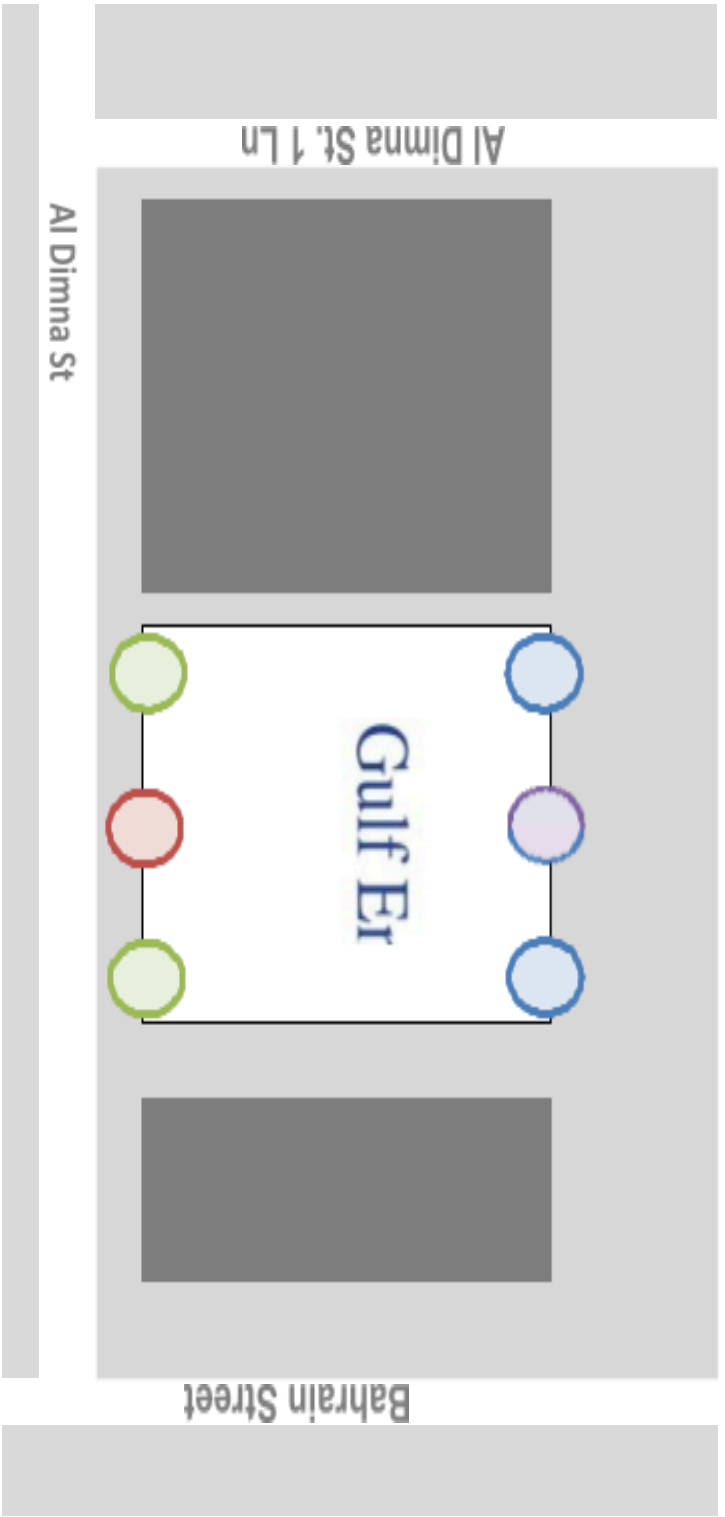





Gate

-  Secondary (Y7-12) + Primary Music from Secondary Basement
-  Secondary (Y7-12), Admin & Visitors
-  Secondary (Y7-12) + Primary PE from Secondary Basement

Gate

-  Primary (Y1-6) + EYFS (from basement)
-  EYFS only
-  Primary (Y1-6) + EYFS (from basement)



**FIRE DRILL
PROCEDURE**
Salmiya Park

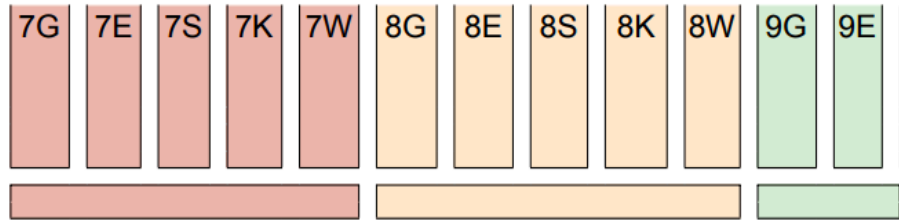
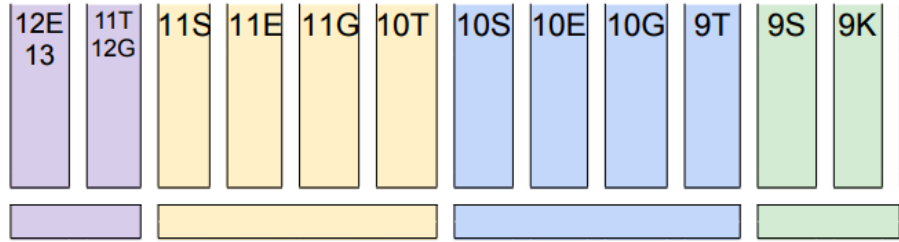

Entrance Park

1. Line up the students in alphabetical order.
2. Give the green/red paper to 1st student. Make sure it's held up high and visible.
3. Wait patiently for follow-up instructions.

SCHOOL

Rooms: 212, 213, 214, 216, 217, 218, 219

Evacuation Route 

Alternate Routes 

Upon reaching the Yard,
Students should proceed to
**Gate 4 (Primary - Internaxonal
Clinic)** to exit the site.



Rooms: 201, 202, 203, 204, 206a, 206, 207

Evacuation Route 

Alternate Routes 

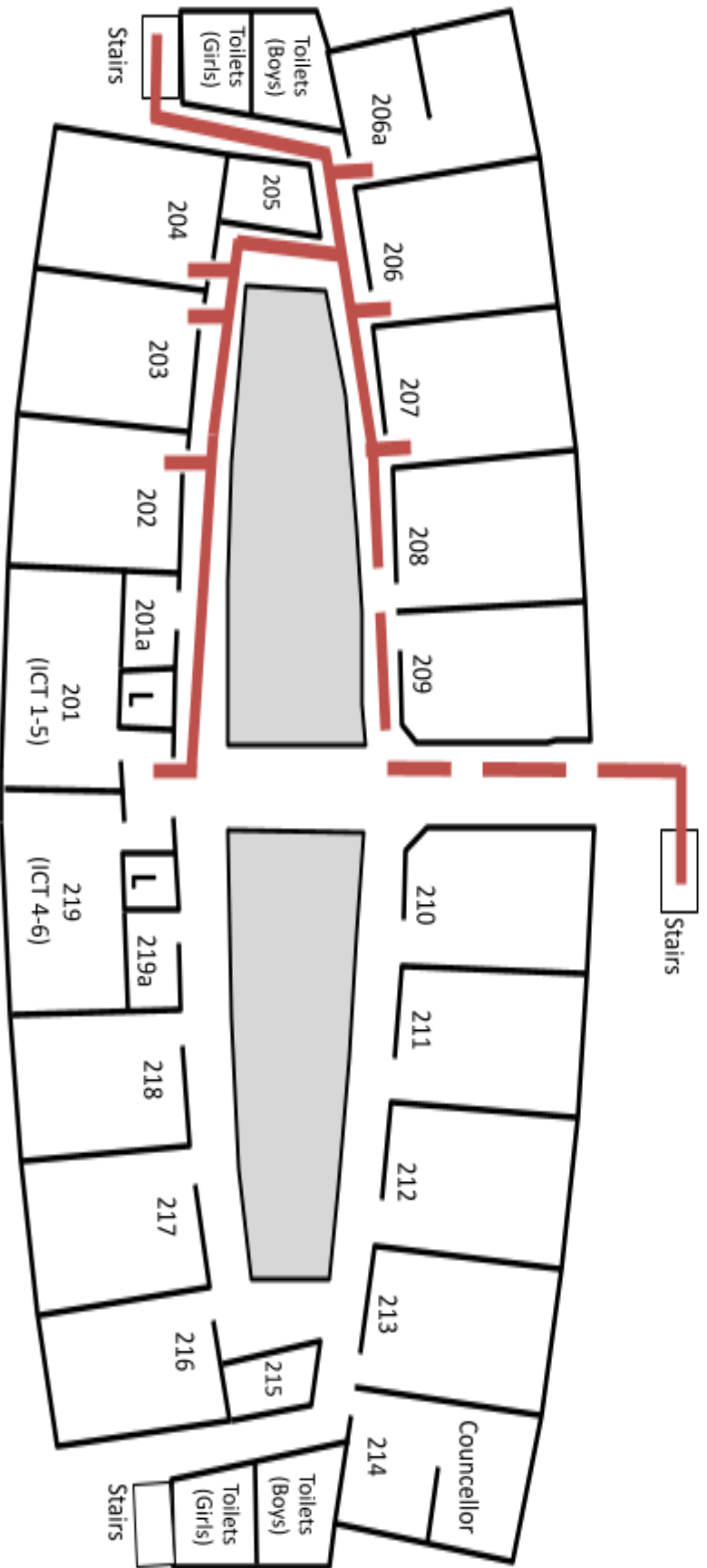

Upon reaching the Yard,
Students should proceed to
Gate 6 (Primary - Khalifa) to
exit the site.

Rooms: 112, 113, 114, 116, 117, 118

Evacuation Route 

Alternate Routes 

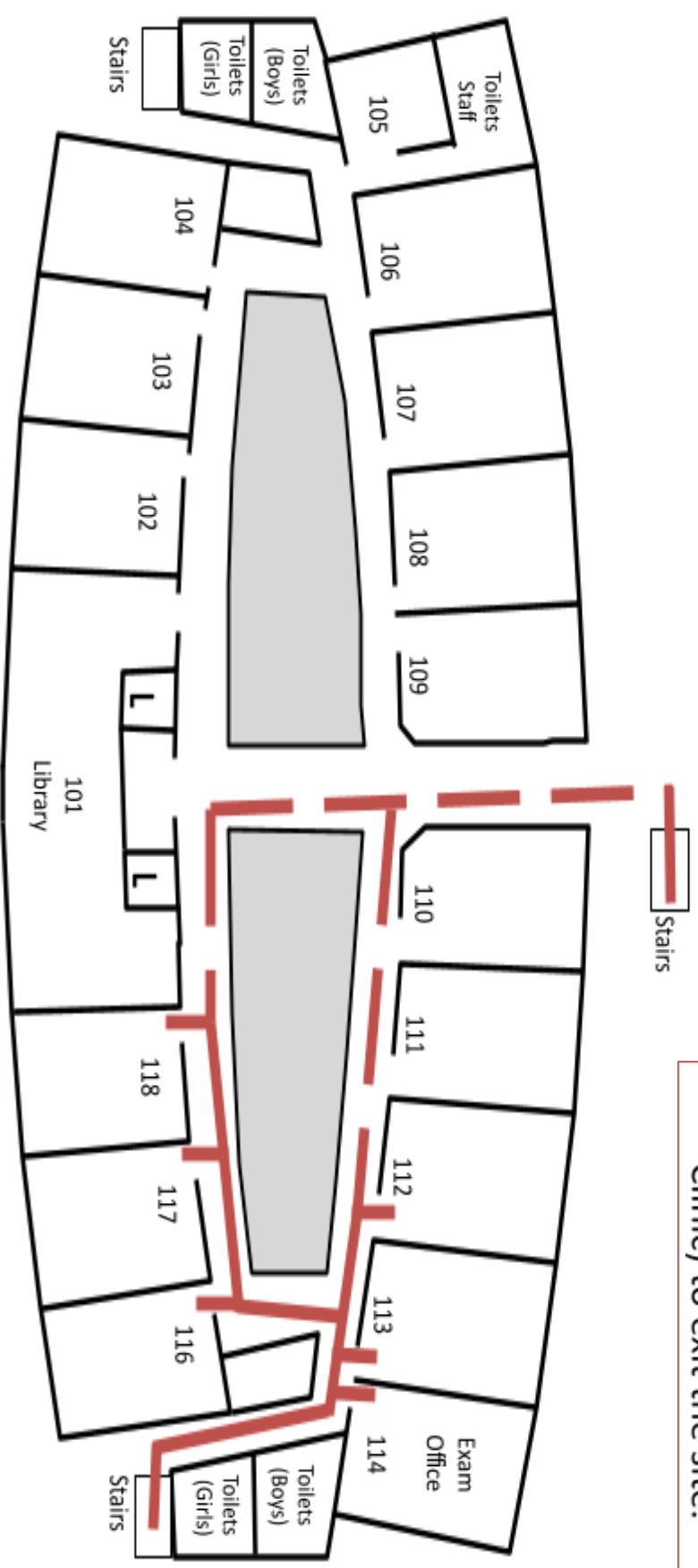

Upon reaching the Yard,
Students should proceed to
**Gate 4 (Primary – InternatXonal
Clinic)** to exit the site.

Rooms: 101, 102, 103, 104, 105, 106, 107

Evacuation Route 

Alternate Routes 

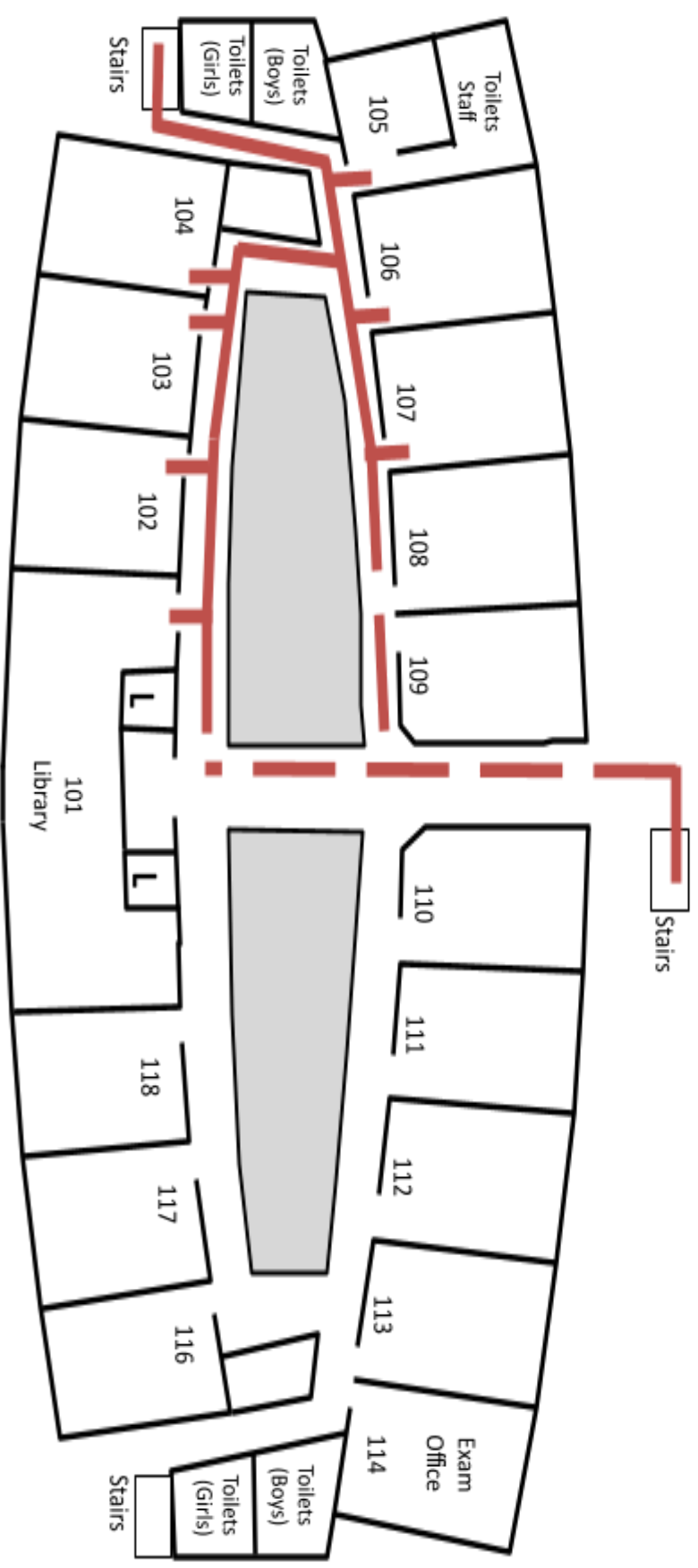

Upon reaching the Yard,
 Students should proceed to
Gate 6 (Primary - Khalifa) to
 exit the site.

Rooms: 108, 109, 110, 111

Evacuation Route 

Alternate Routes 

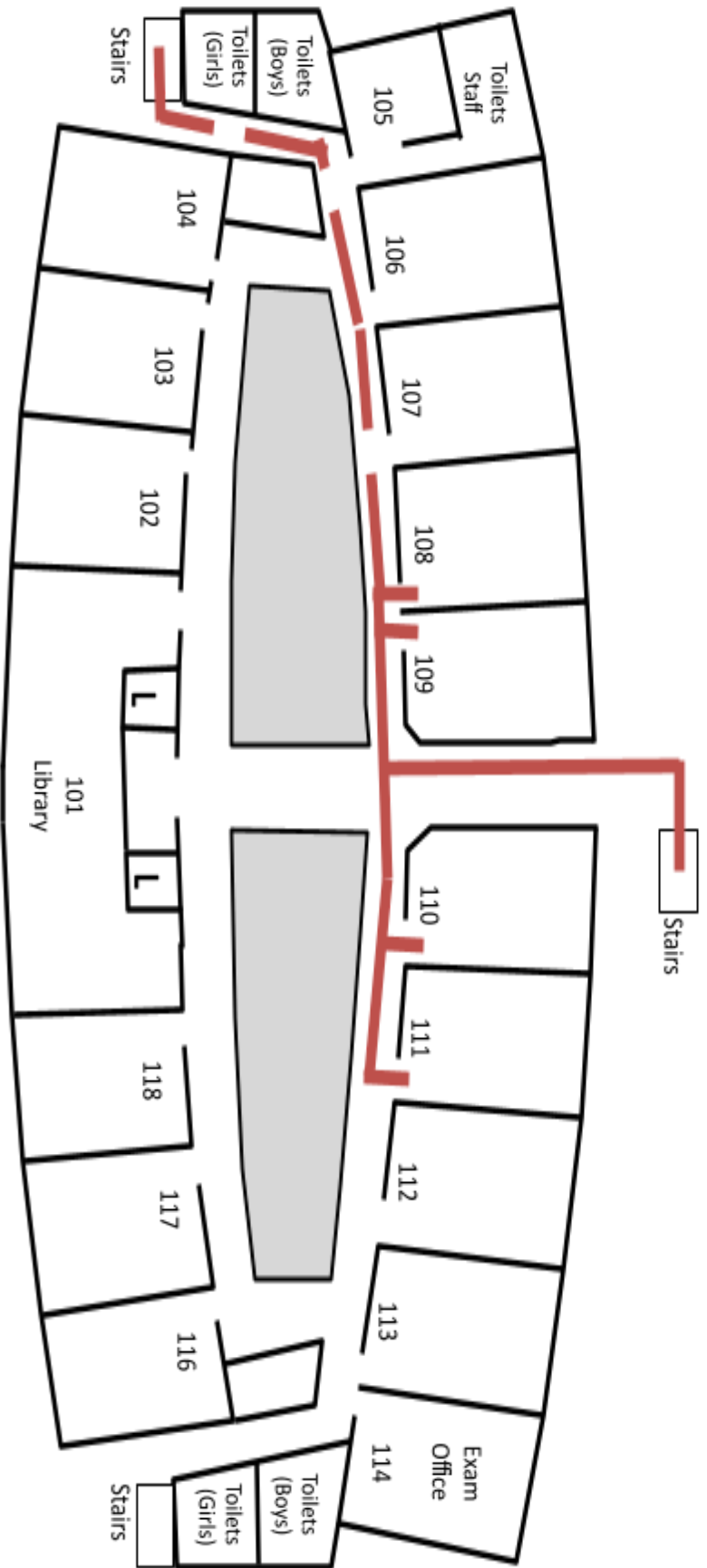

Upon reaching the Yard,
Students should proceed to
Gate 6 (Primary - Khalifa) to
exit the site.

Rooms: G4, G5, G6, G7, G8

Evacuation Route _____

Alternate Routes _____

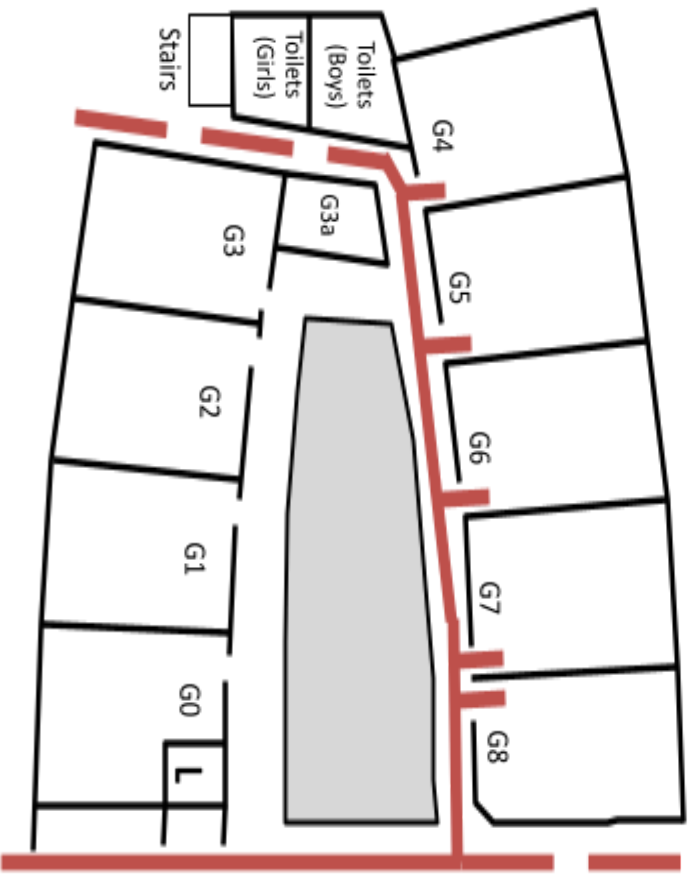

YARD

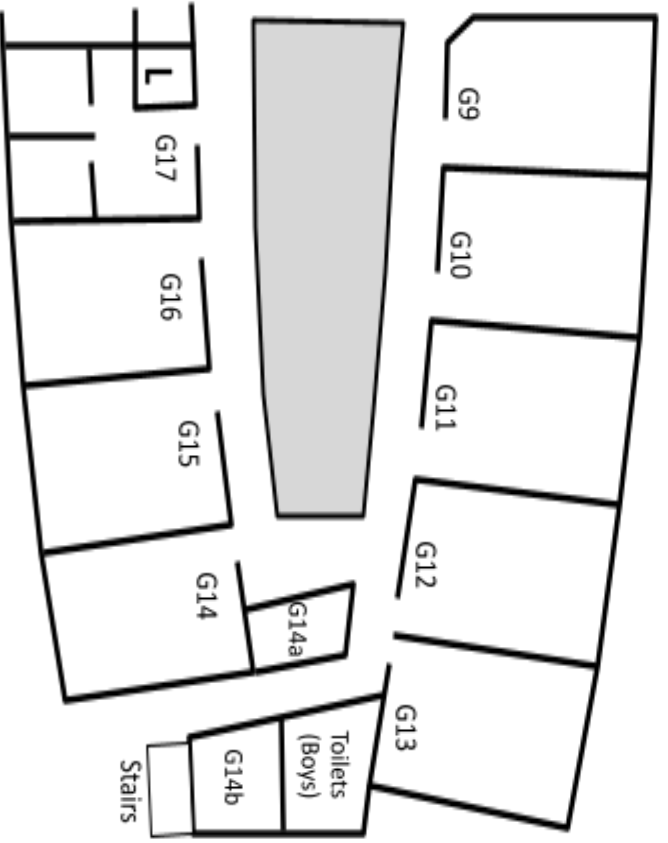

If taking alternate route via Yard, upon reaching the Yard, Students should proceed to Gate 6 (Primary - Khalifa) to exit the site.

Rooms: G3, G2, G1, G0

Evacuation Route _____

Alternate Routes _____

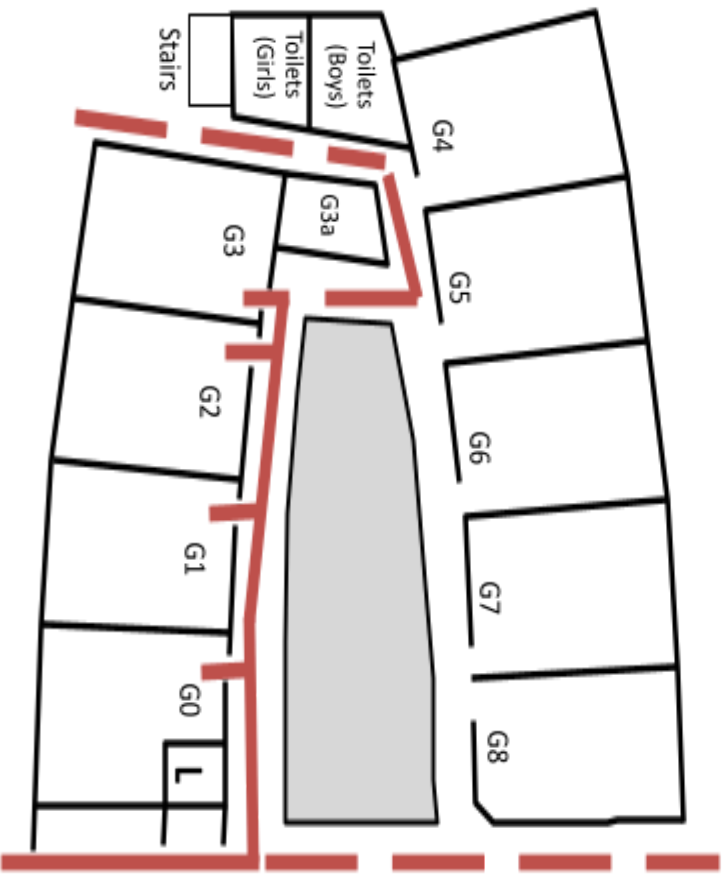

YARD

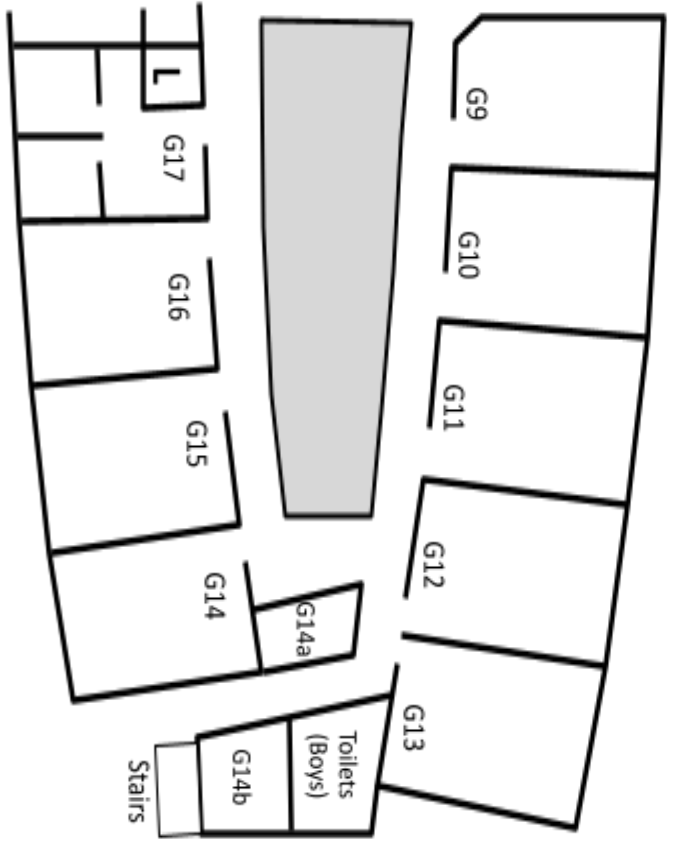

If taking alternate route via Yard, upon reaching the Yard, Students should proceed to Gate 6 (Primary - Khalifa) to exit the site.

Rooms: G17, G16, G15, G14

Evacuation Route _____

Alternate Routes _____

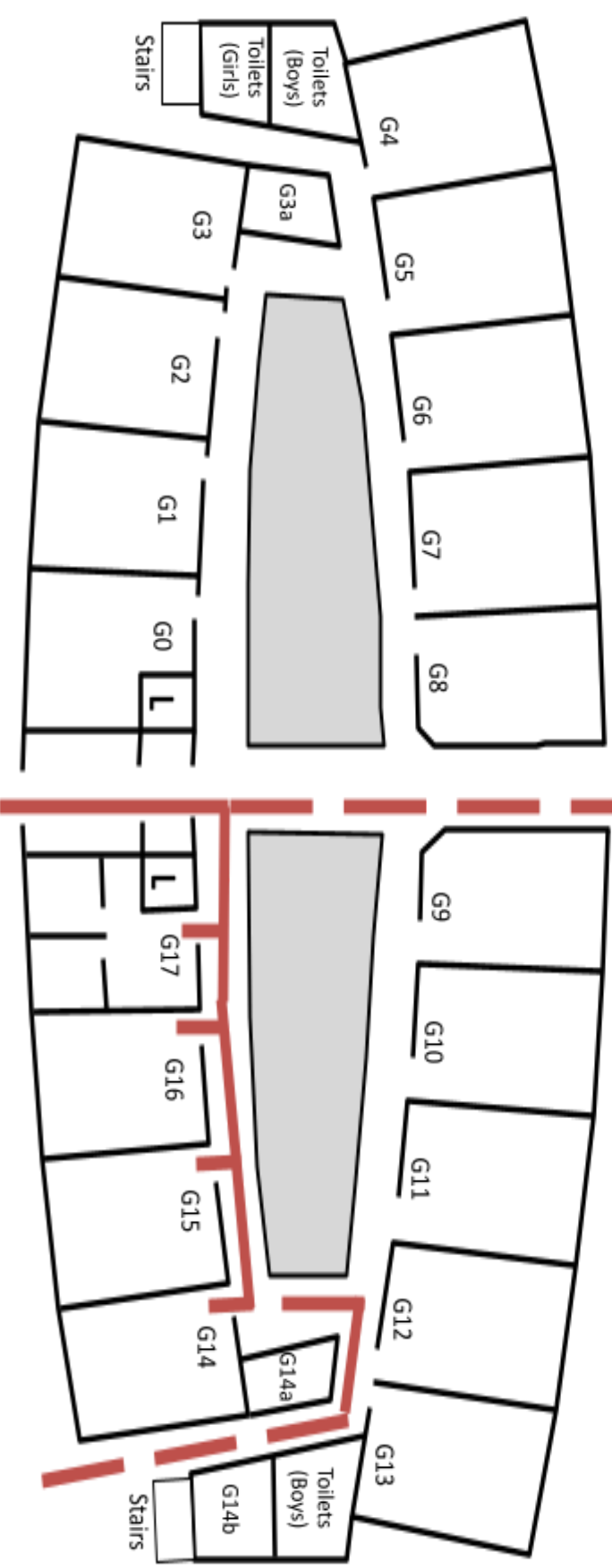

If taking alternate route via Yard, upon reaching the Yard, Students should proceed to Gate 4 (Primary – InternatXonal Clinic) to exit the site.

Rooms: G9, G10, G11, G12, G13

Evacuation Route _____

Alternate Routes _____

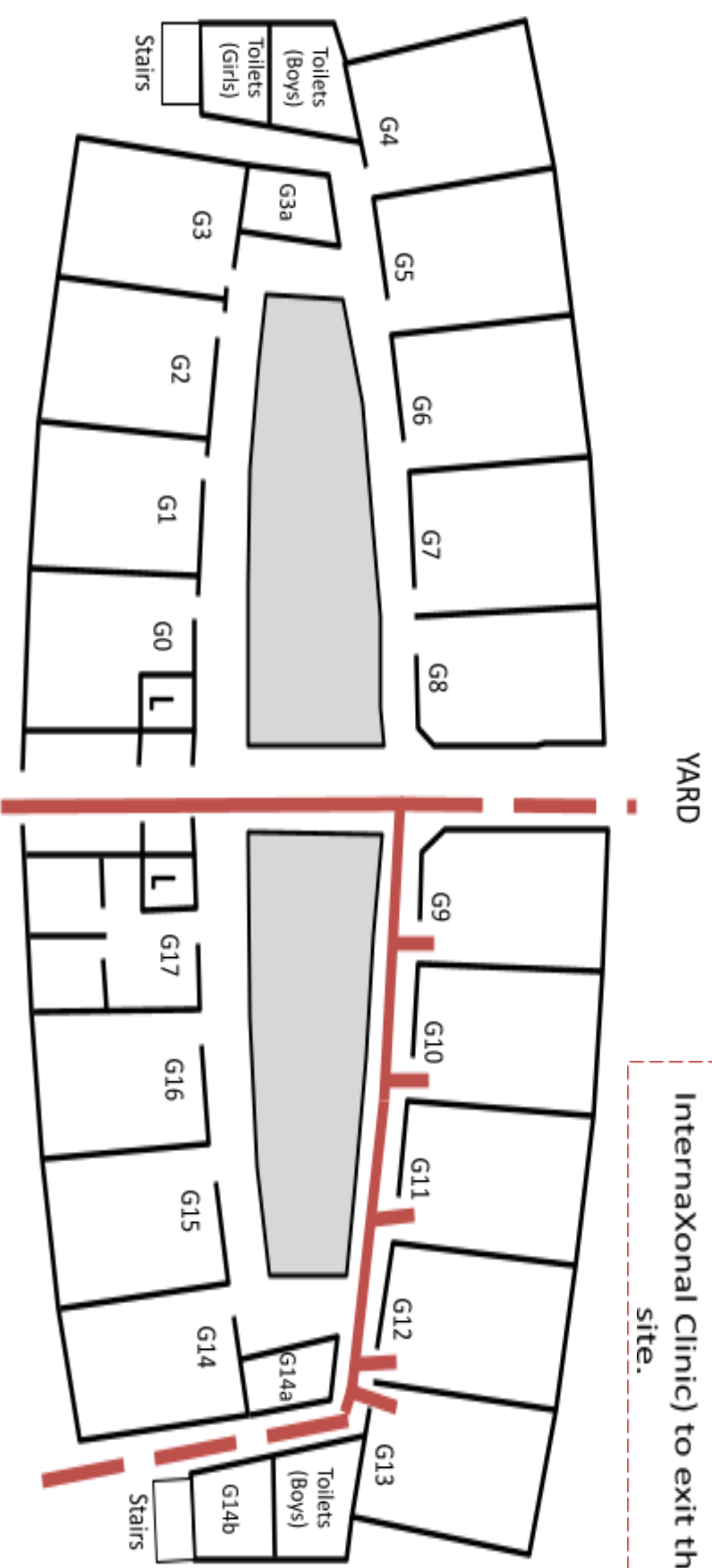

If taking alternate route via Yard, upon reaching the Yard, Students should proceed to Gate 4 (Primary – InternatXonal Clinic) to exit the site.

Rooms: B7, B8, B1, B2

Evacuation Route _____

Alternate Routes _____

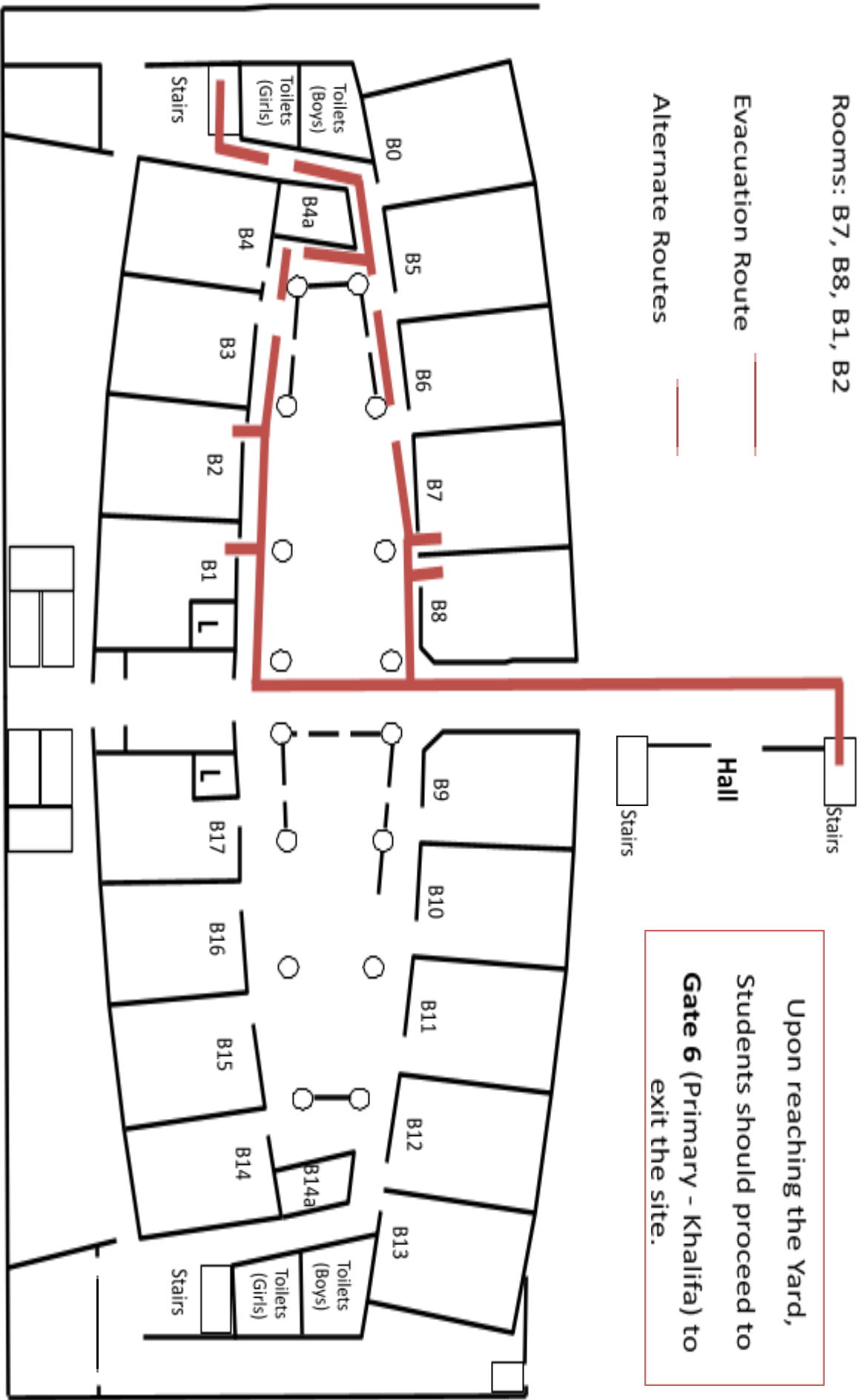

Upon reaching the Yard,
Students should proceed to
Gate 6 (Primary - Khalifa) to
exit the site.

Rooms: B0, B5, B6, B4, B3

Evacuation Route _____

Alternate Routes _____

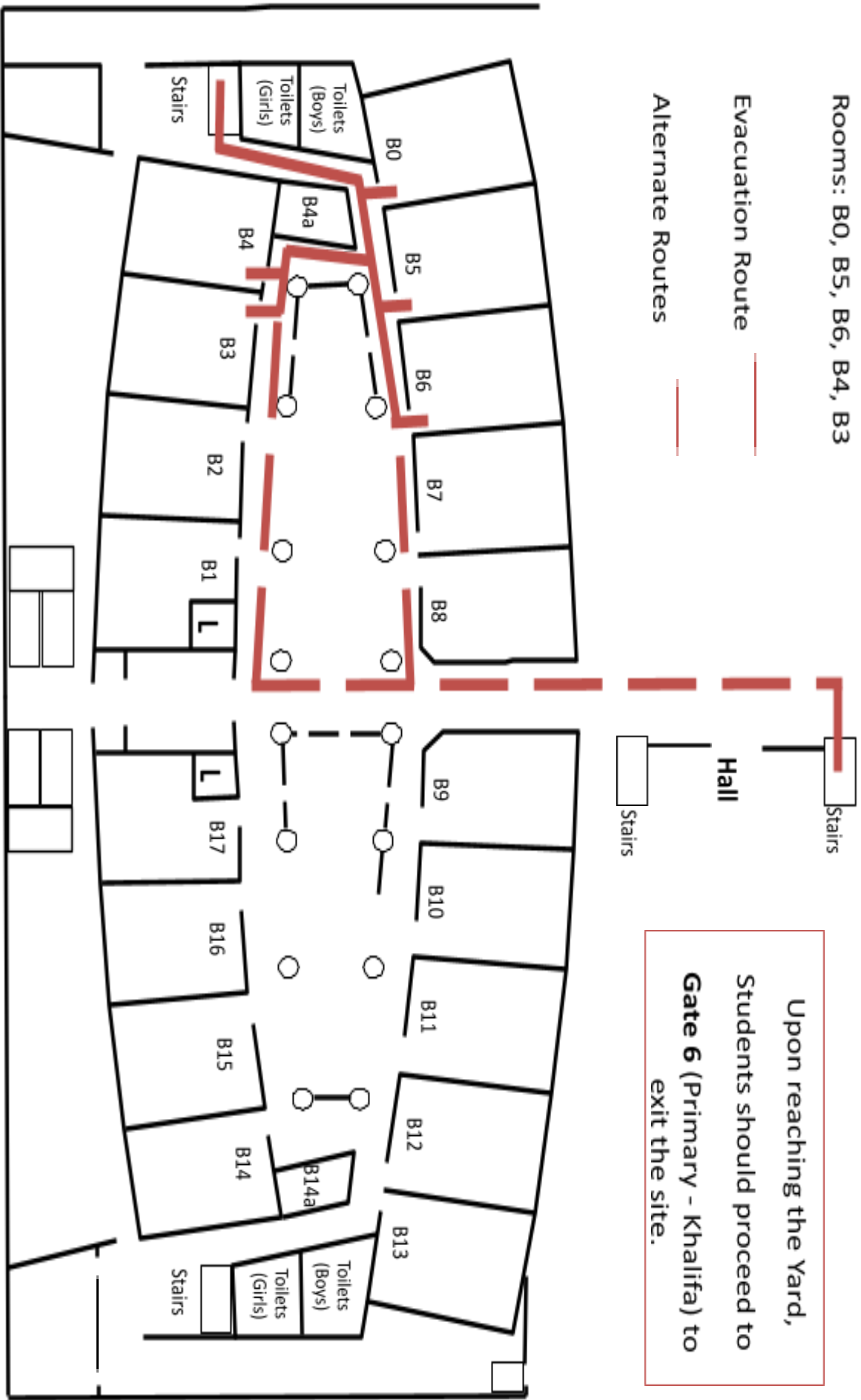

Upon reaching the Yard,
Students should proceed to
Gate 6 (Primary - Khalifa) to
exit the site.

Rooms: B9, B10, B17, B16

Evacuation Route _____

Alternate Routes _____

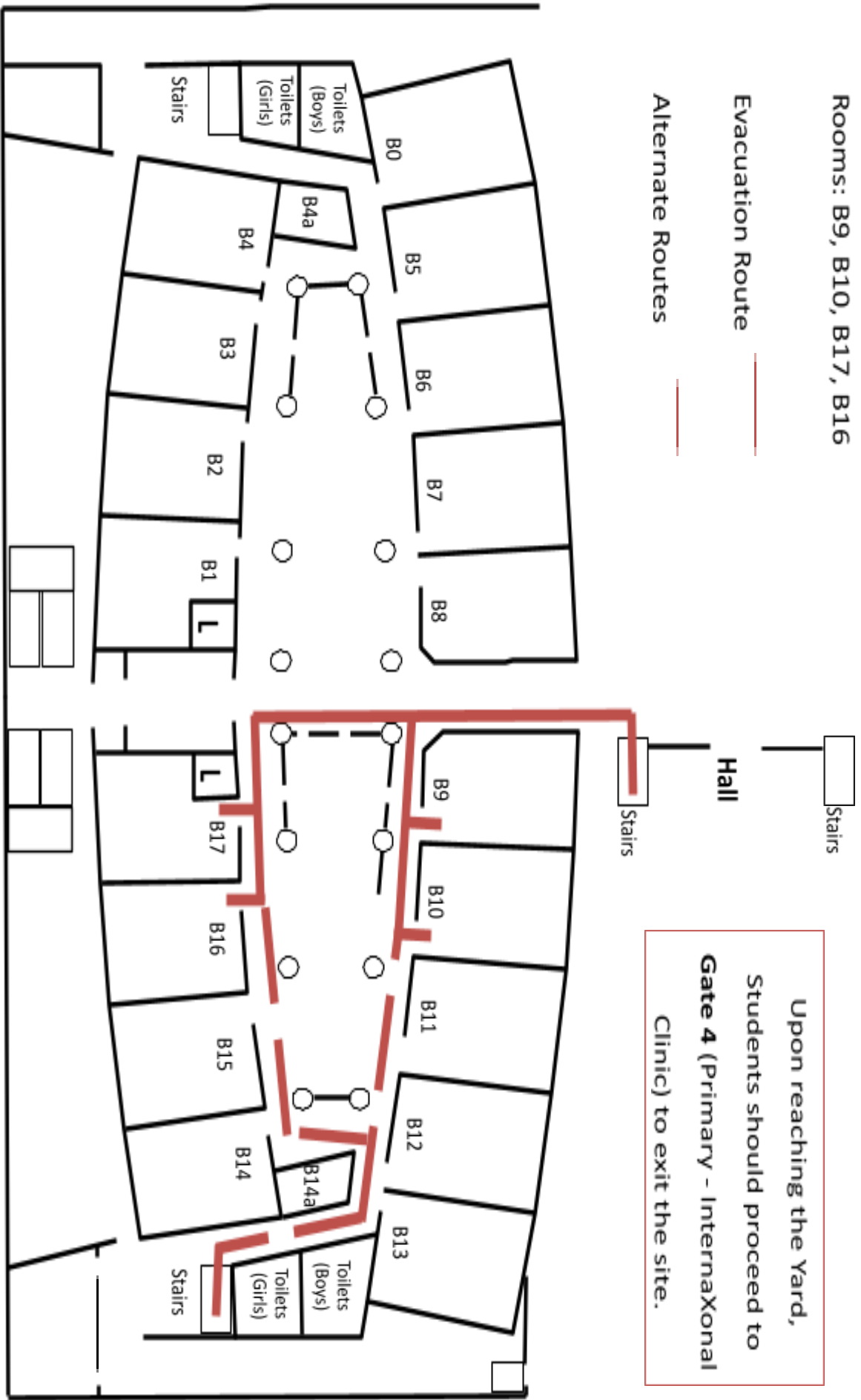

Upon reaching the Yard,
Students should proceed to
**Gate 4 (Primary - Internaxonal
Clinic)** to exit the site.

Rooms: B11, B12, B13, B15, B14

Evacuation Route _____

Alternate Routes _____

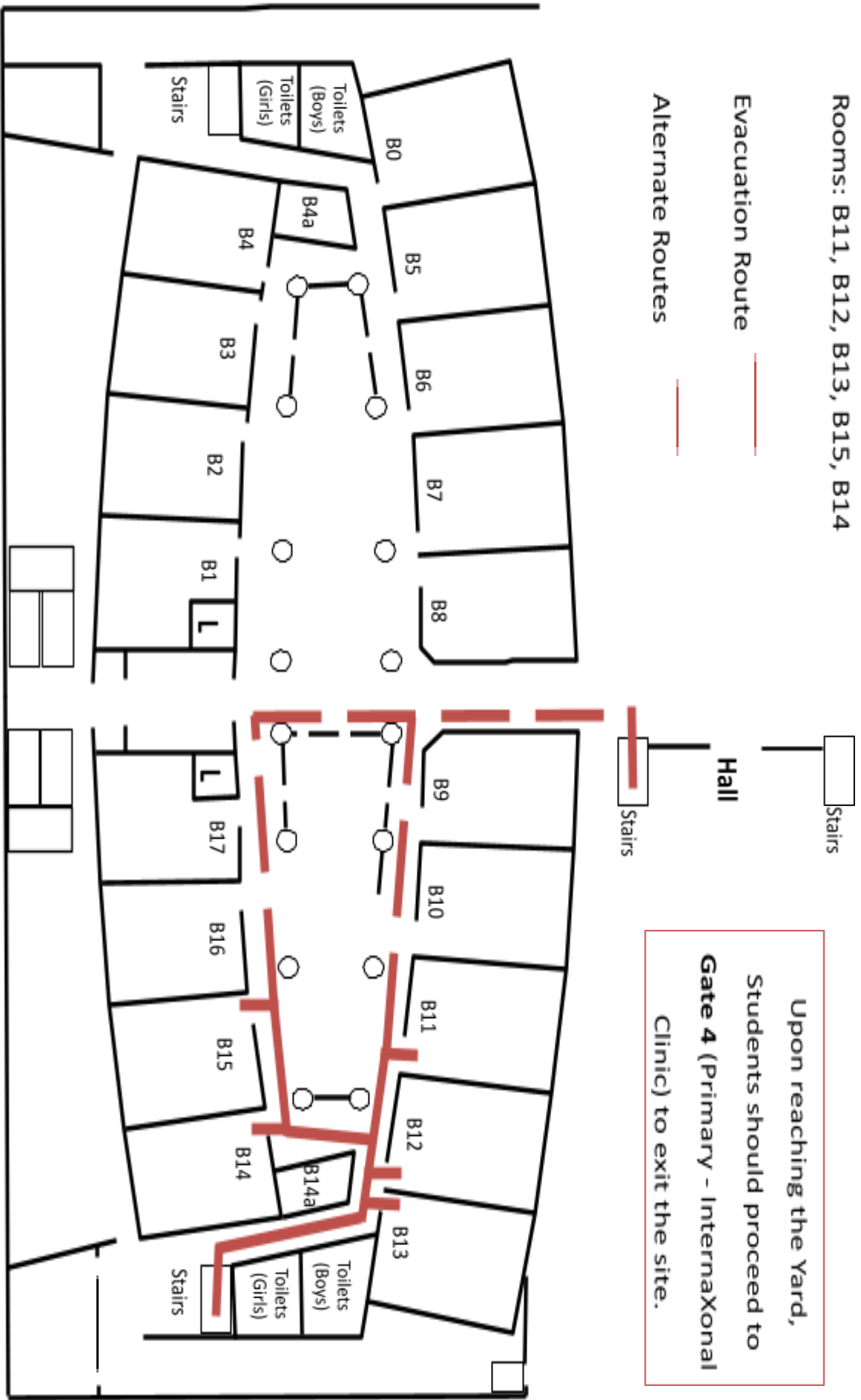

Upon reaching the Yard,
Students should proceed to
**Gate 4 (Primary - Internaxonal
Clinic)** to exit the site.

Rooms: B22, B23, B24, B25, B26, B27,
B21, B20, B19

Evacuation Route ———

Alternate Routes ———

SECONDARY

Upon reaching the Yard,
Students should proceed
to **Gate 1** (Secondary –
Khalifa) to exit the site.

PRIMARY

Upon reaching the Yard,
Students should proceed
to **Gate 1** (Primary –
Khalifa) to exit the site.

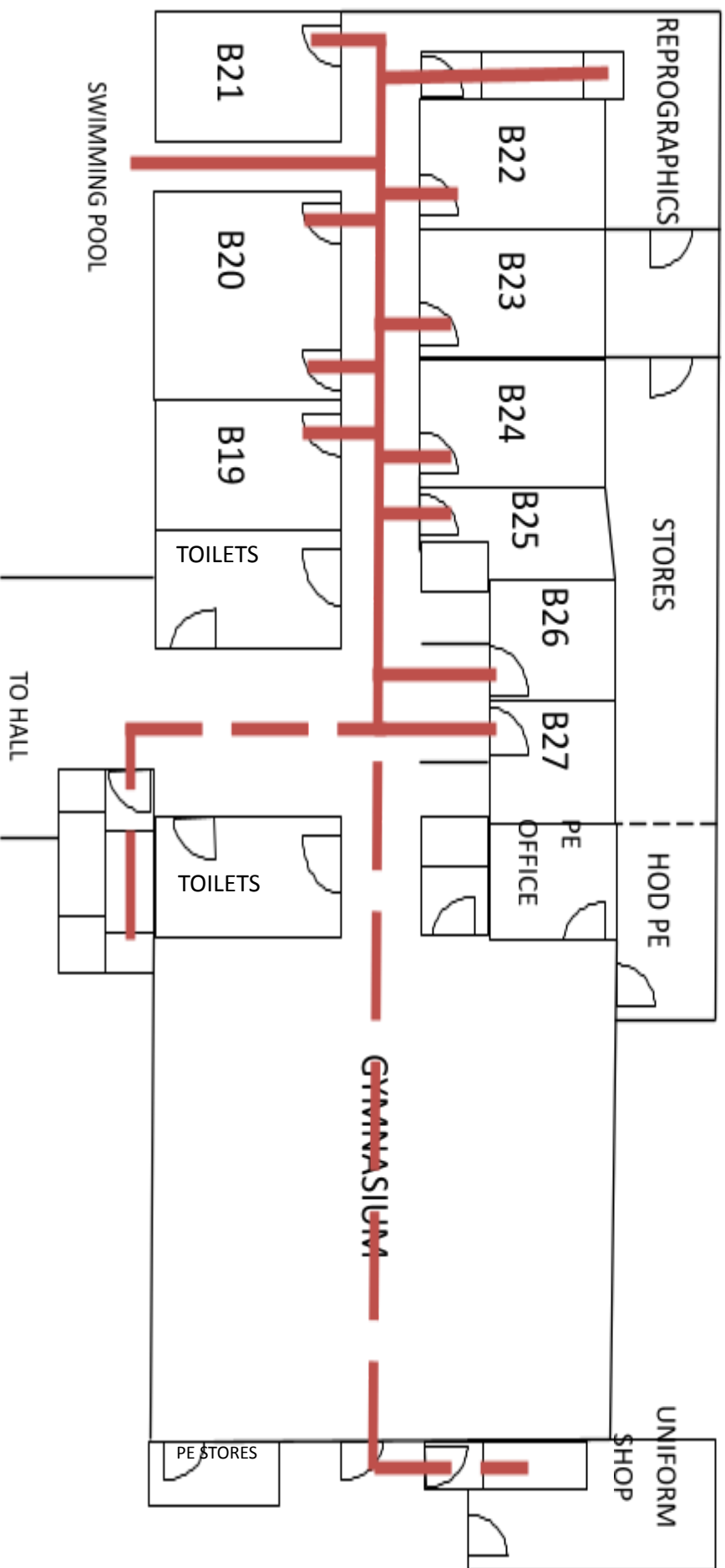

Rooms: Gymnasium

Evacuation Route

Alternate Routes

SECONDARY

Upon reaching the Yard,

Students should proceed to **Gate 3** (Secondary – Internaxonal Clinic) to exit the site.

PRIMARY

Upon reaching the Yard,

Students should proceed to **Gate 3** (Primary – Internaxonal Clinic) to exit the site.

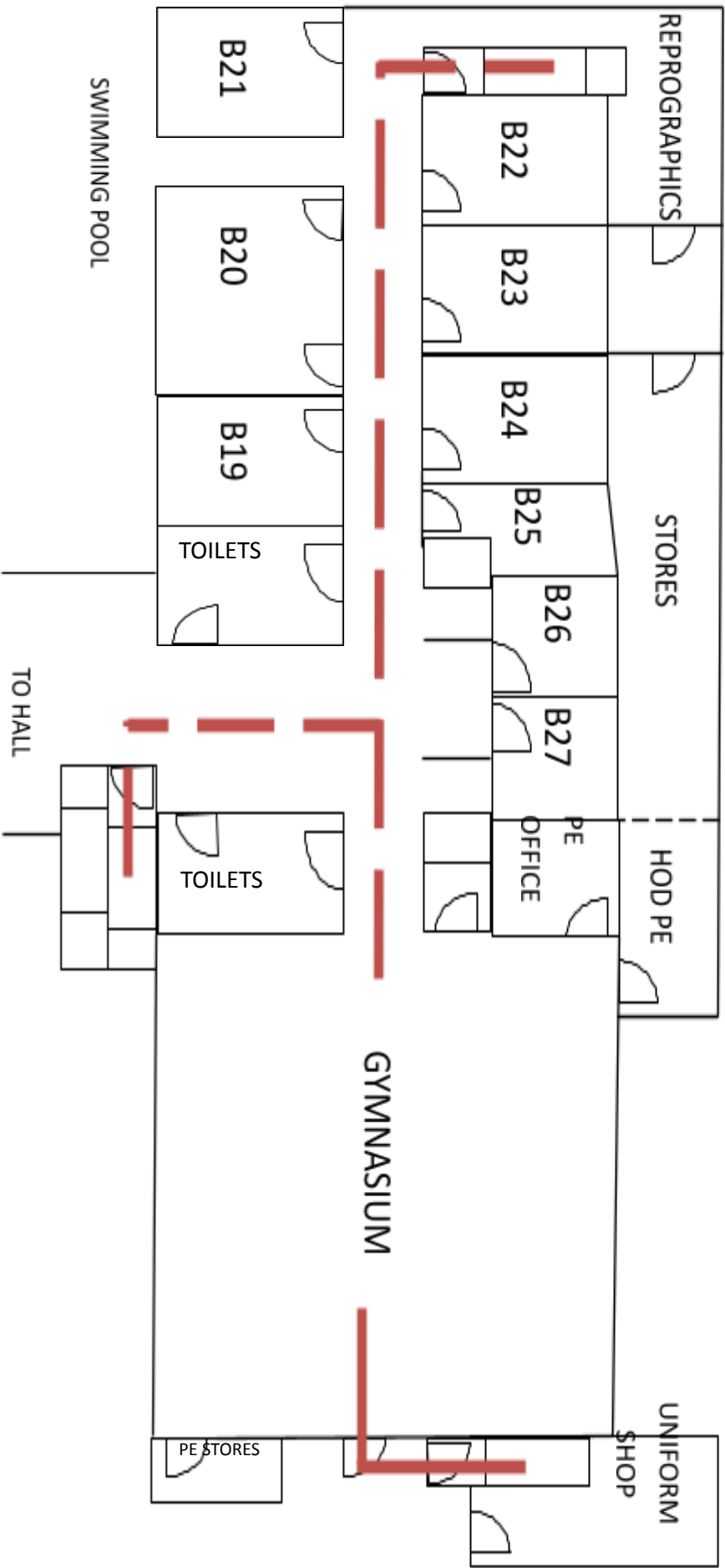

Rooms: Hall

Evacuation Route _____

Alternate Routes _____

SECONDARY

Upon reaching the Yard,
Students should proceed
to **Gate 3** (Secondary –
InternatXonal Clinic) to
exit the site.

PRIMARY

Upon reaching the Yard,
Students should proceed
to **Gate 4** (Primary –
InternatXonal Clinic) to
exit the site.

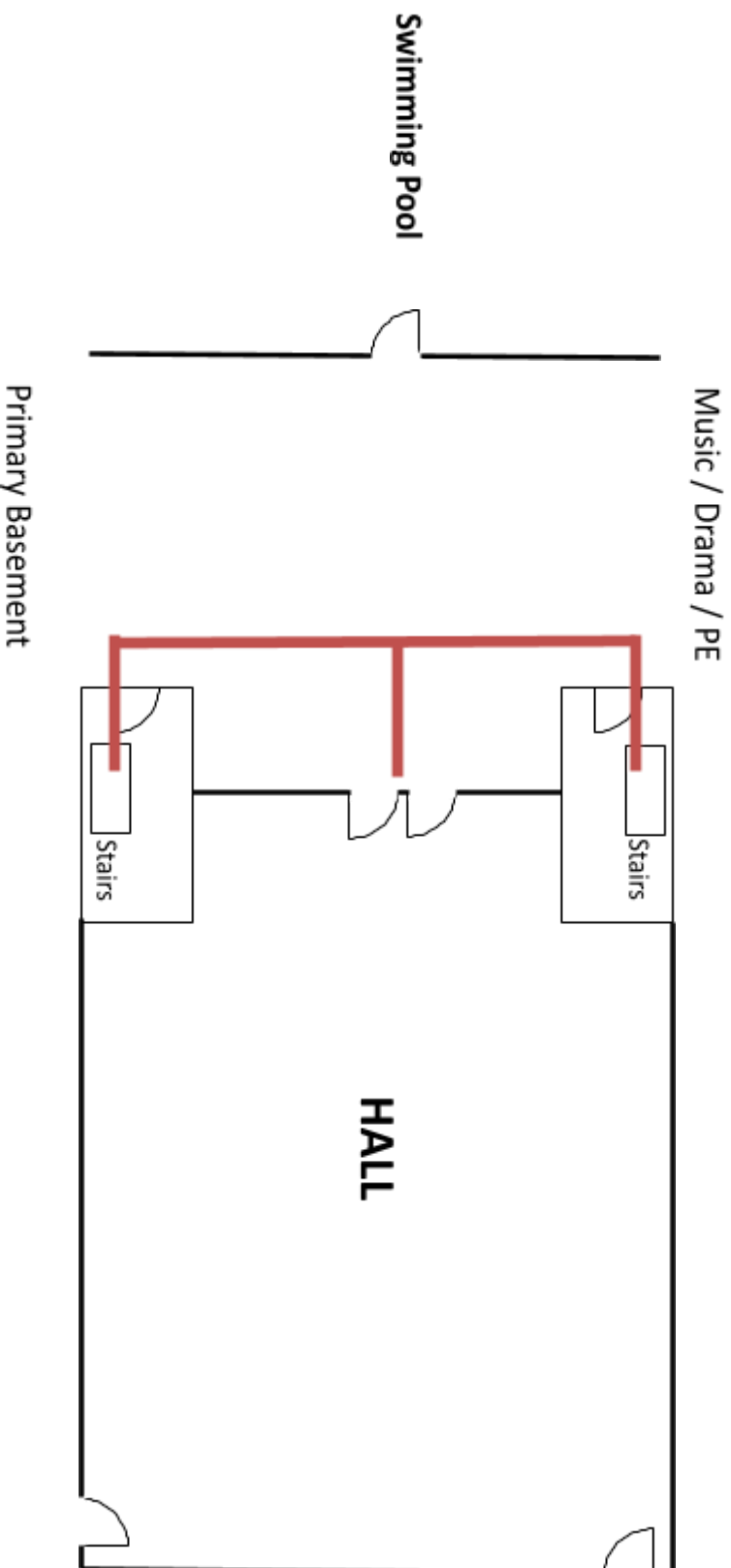

Rooms: Lab 10, Lab 11, Lab 12

Evacuation Route _____

Alternate Routes _____

Secondary School

Upon reaching the Yard,
Students should proceed to
**Gate 3 (Secondary -
Internaxonal Clinic)** to exit the
site.

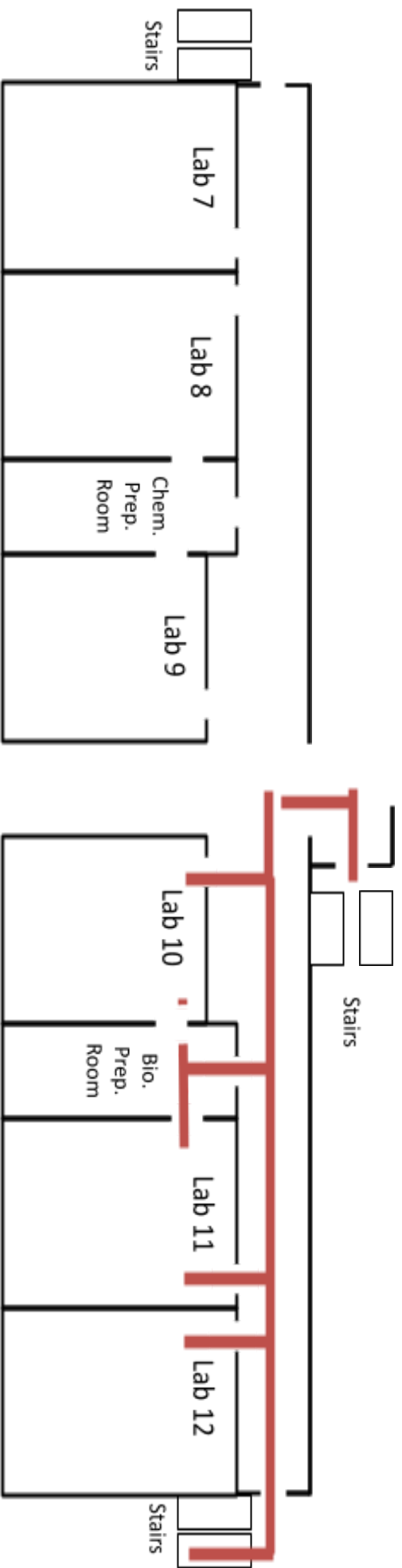

Primary School

Rooms: Lab 7, Lab 8, Lab 9

Evacuation Route 

Alternate Routes 

Upon reaching the Yard,
Students should proceed to
Gate 1 (Secondary - Khalifa) to
exit the site.

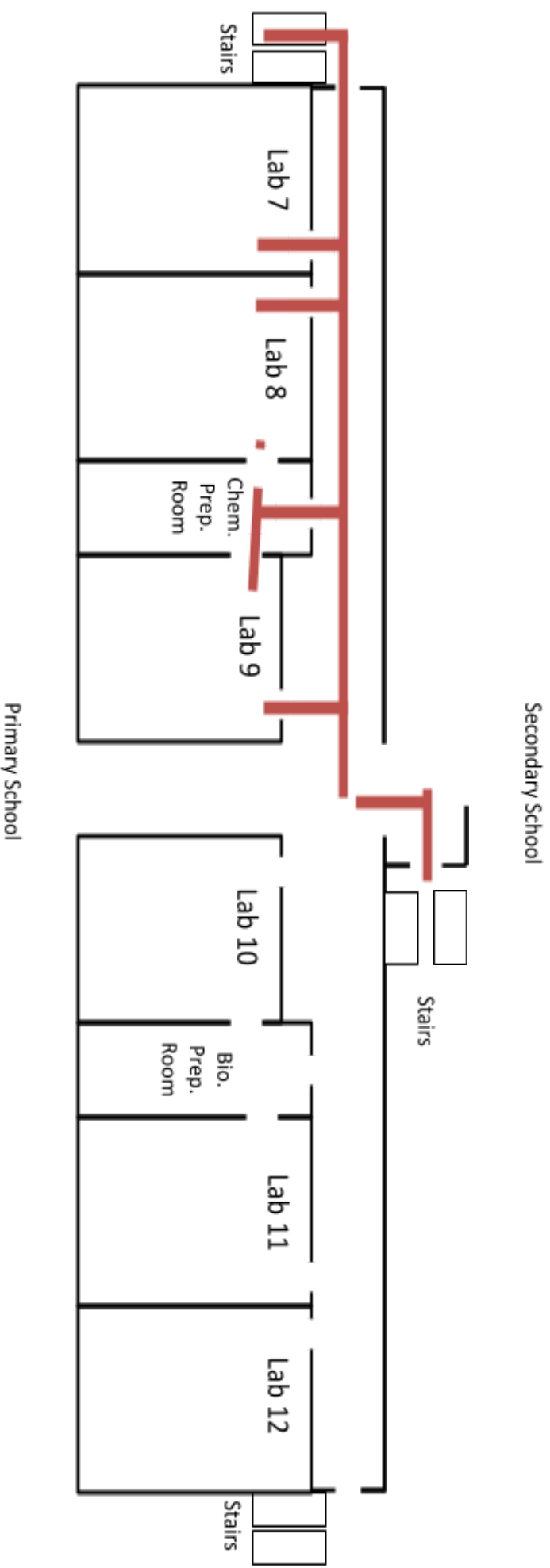

Rooms: Lab 4, Lab 5, Lab 6

Evacuation Route 

Alternate Routes 

Secondary School

Upon reaching the Yard,
Students should proceed to
**Gate 3 (Secondary -
Internaxonal Clinic)** to exit the
site.

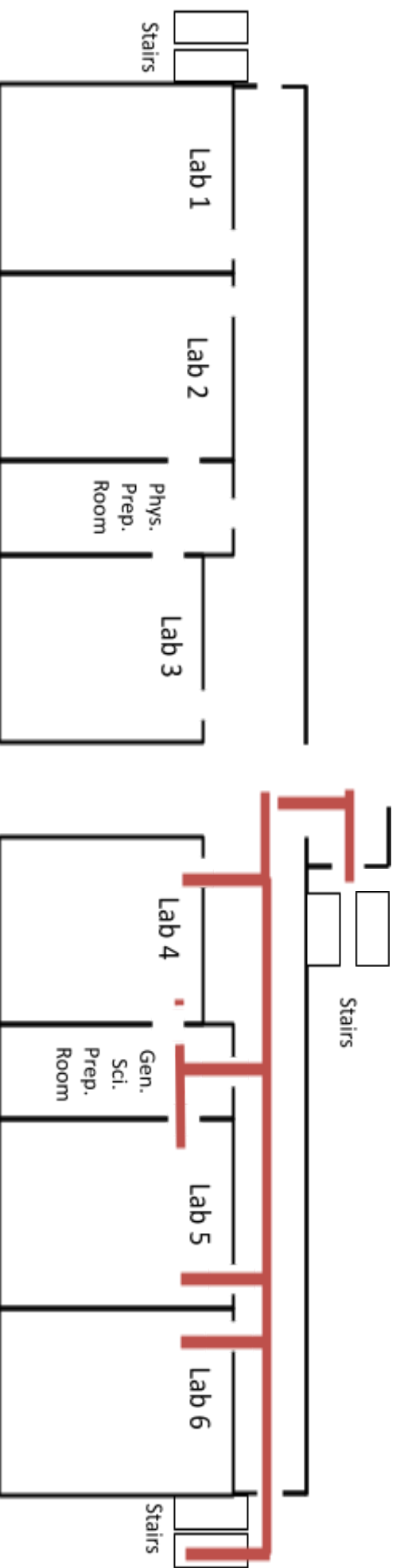

Primary School

Rooms: Lab 1, Lab 2, Lab 3

Evacuation Route 

Alternate Routes 

Upon reaching the Yard,
Students should proceed to
Gate 1 (Secondary - Khalifa) to
exit the site.

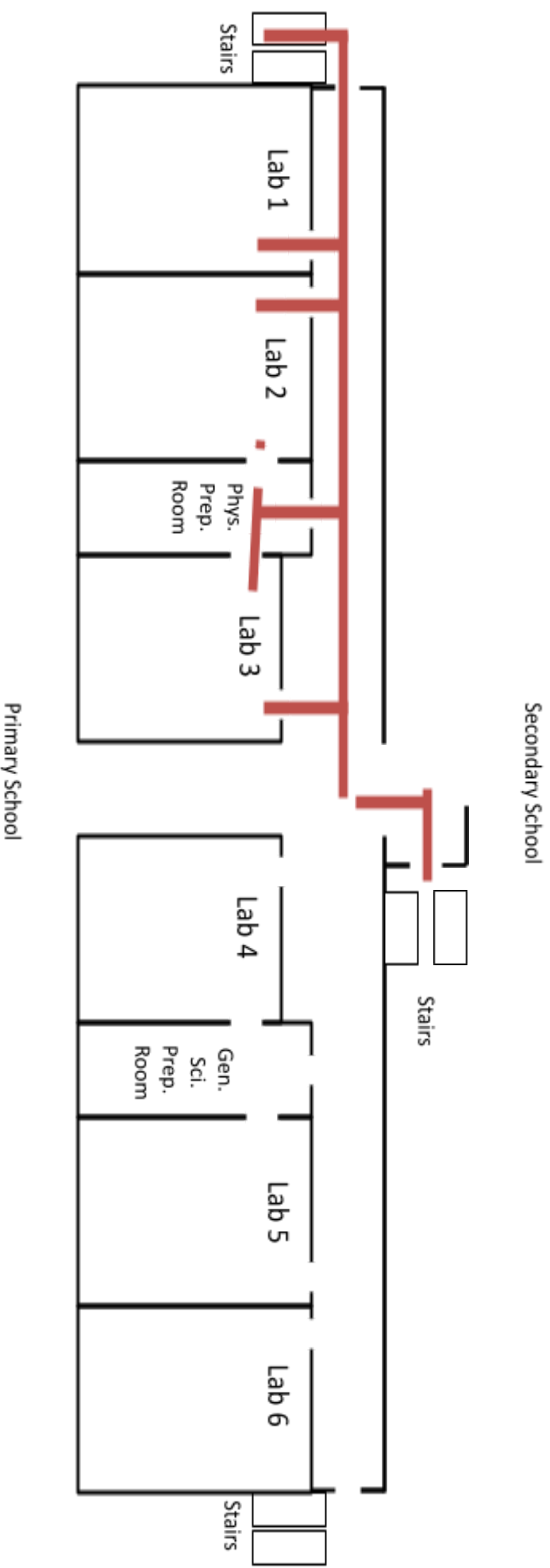

Rooms: Lab 10, Lab 11, Lab 12

Evacuation Route _____

Alternate Routes _____

Secondary School

Upon reaching the Yard,
Students should proceed to
**Gate 3 (Secondary -
Internaxonal Clinic)** to exit the
site.

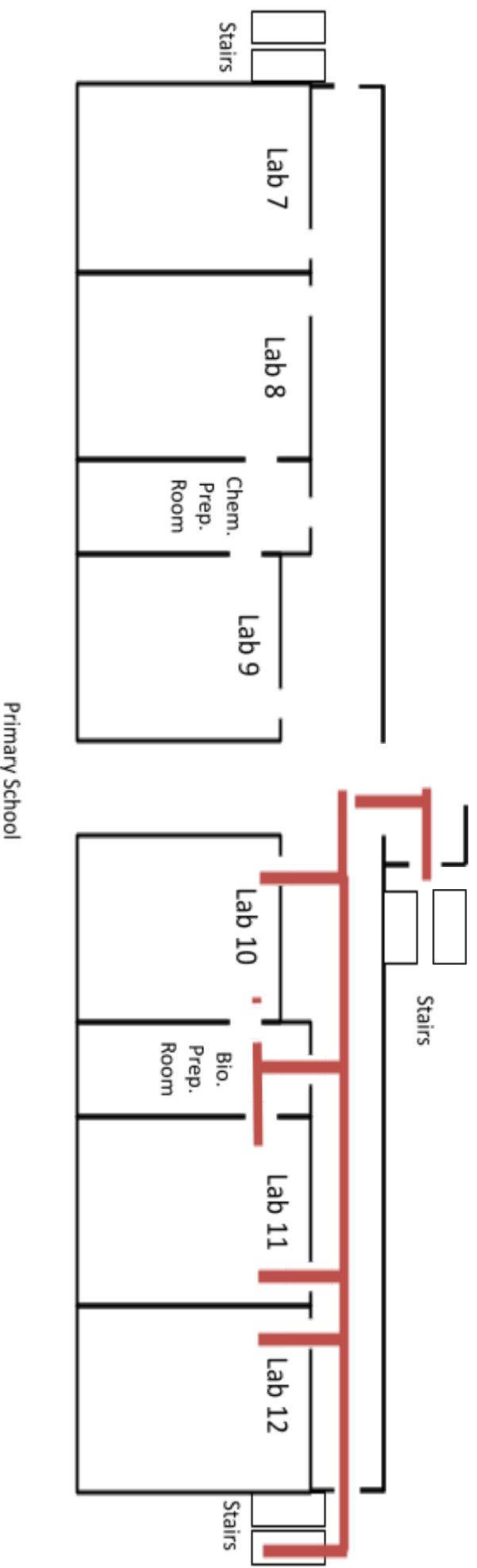

Rooms: G32, G33, G34, G35, G36, G37, G38

Evacuation Route _____

Alternate Routes _____

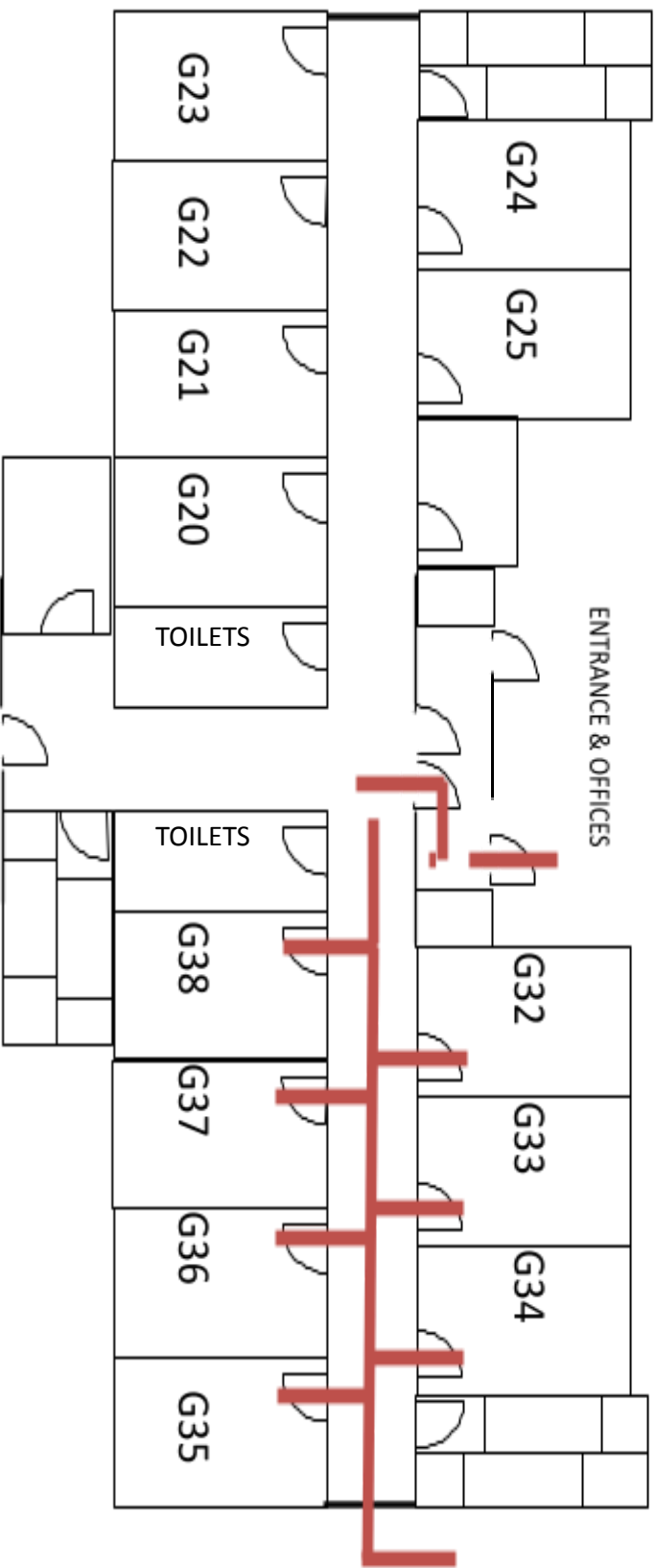

Upon reaching the Yard,
Students should proceed to
**Gate 3 (Secondary -
Internaxonal Clinic)** to exit the
site.

Rooms: G20, G21, G22, G23, G24, G25

Evacuation Route _____

Alternate Routes _____

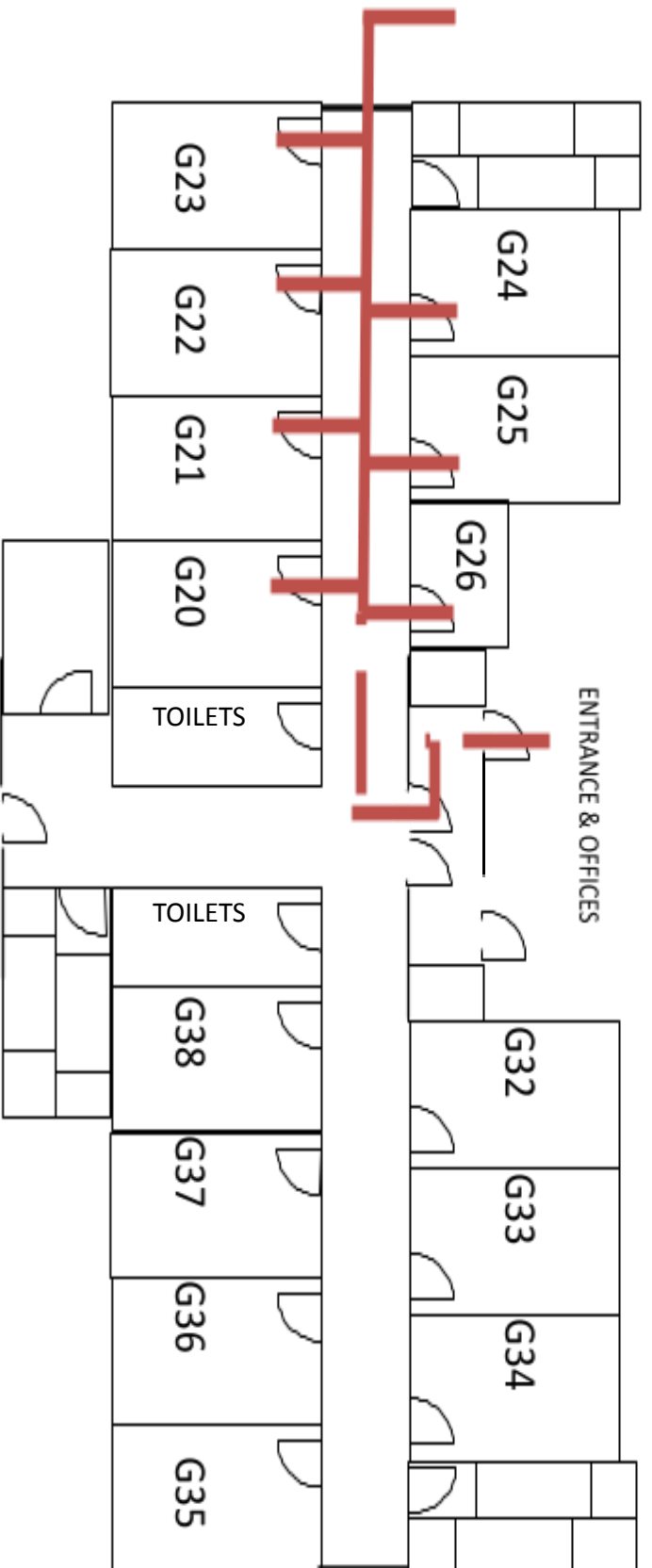

Upon reaching the Yard,
Students should proceed to
Gate 1 (Secondary - Khalifa) to
exit the site.

Rooms: 129, 130, 131, 132, 133, 134, 135

Evacuation Route _____

Alternate Routes _____



Upon reaching the Yard,
Students should proceed to
**Gate 3 (Secondary –
International Clinic)** to exit the
site.

Rooms: Library

Evacuation Route _____

Alternate Routes _____



Upon reaching the Yard,
Students should proceed to
Gate 1 (Secondary - Khalifa) to
exit the site.

Rooms: 228, 229

Evacuation Route _____

Alternate Routes _____

Upon reaching the Yard,
Students should proceed to
**Gate 3 (Secondary –
Internaxonal Clinic)** to exit the
site.

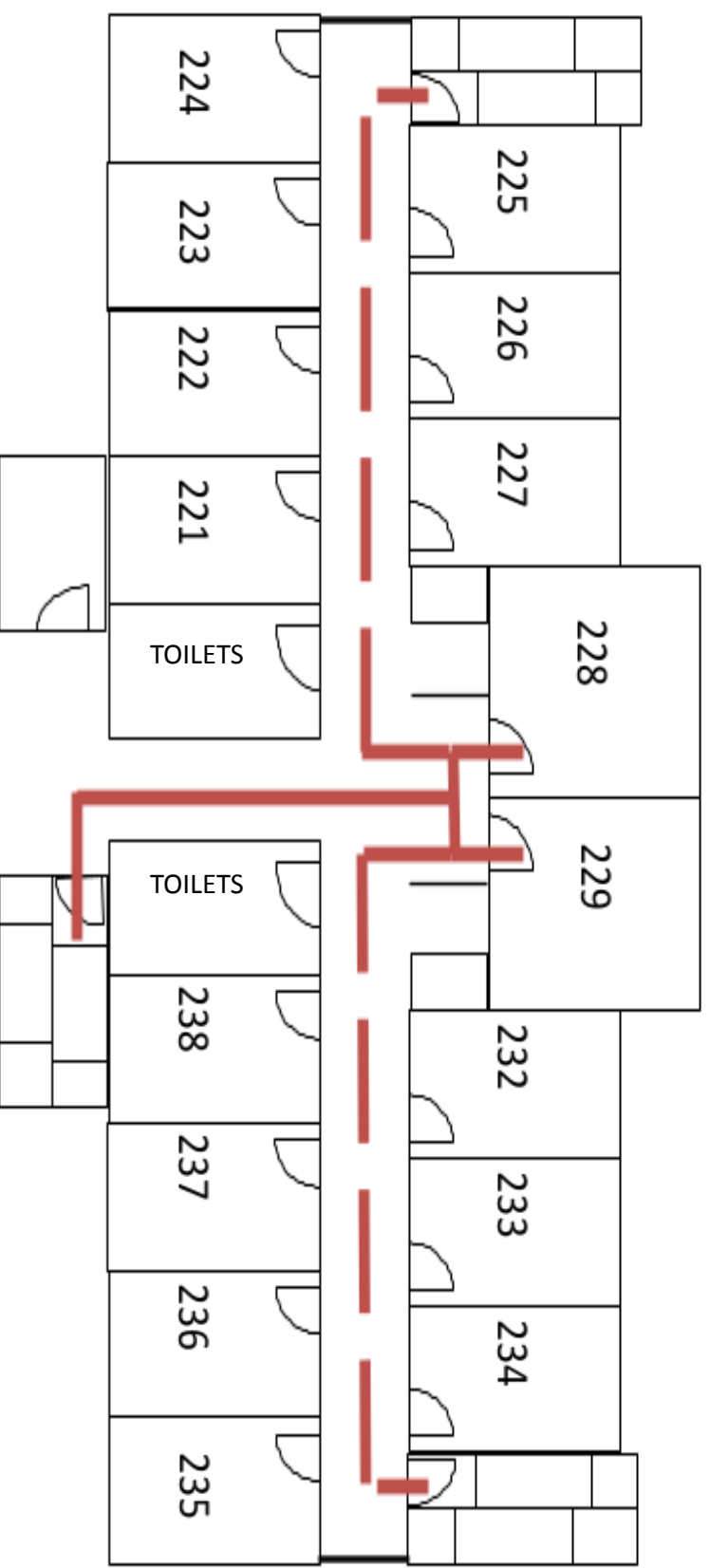

Rooms: 232, 233, 234, 235, 236, 237, 238

Evacuation Route _____

Alternate Routes _____

Upon reaching the Yard,
Students should proceed to
**Gate 3 (Secondary –
International Clinic)** to exit the
site.



Rooms: 221, 222, 223, 224, 225, 226, 227

Evacuation Route _____

Alternate Routes _____

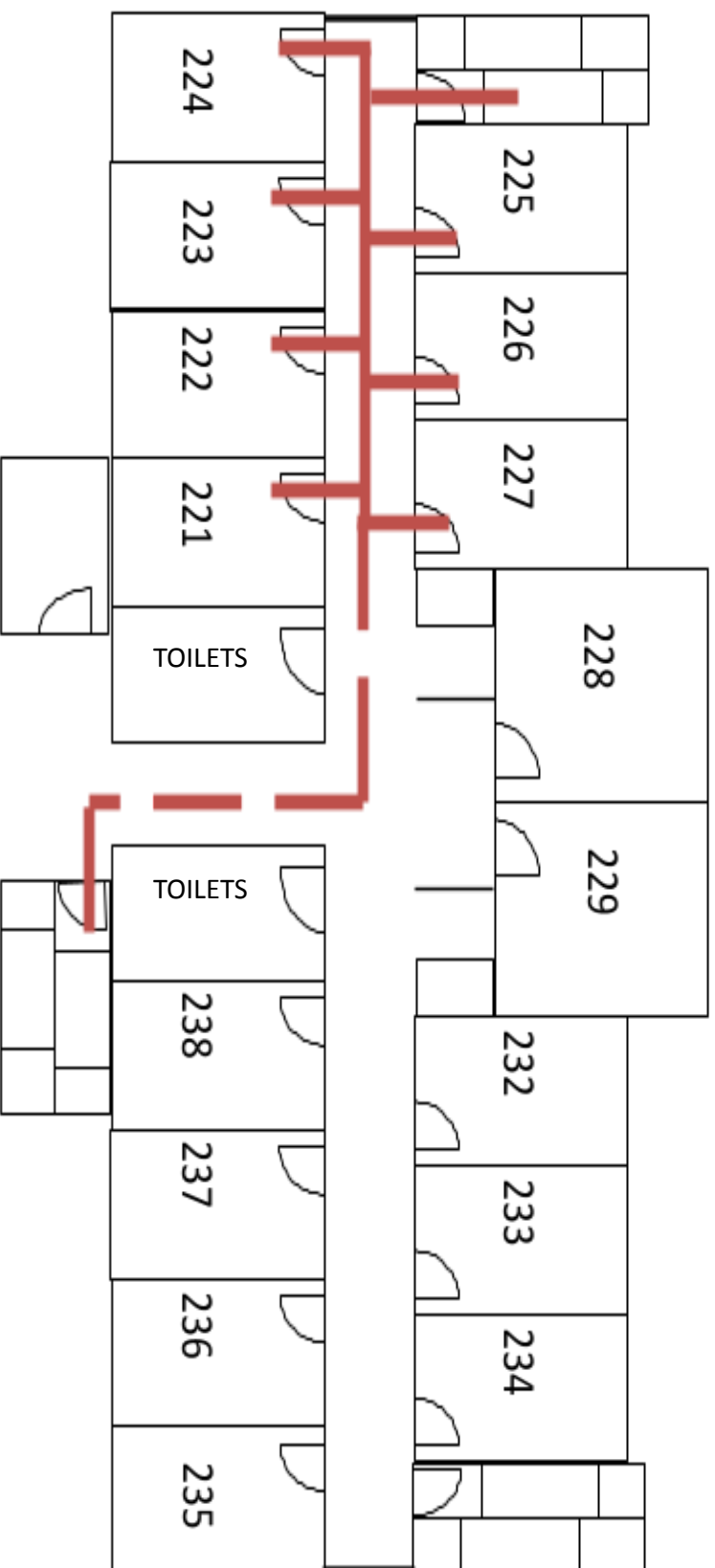

Upon reaching the Yard,
 Students should proceed to
Gate 1 (Secondary – Khalifa)
 to exit the site.

YOUR ROLE

STUDENTS

- Students should remain calm and quiet, listening to instructions from teaching staff
- They should leave the building following the route requested
- They should assemble in an orderly fashion in their classes at their designated assembly point

CLASS / FORM TEACHERS

- If teaching should direct students as to the correct route out of the building.
- Should be visible at the Class / Form Assembly point and take register to identify any missing students (Inform YL / HOY).
- Should ensure students are organised, calm and quiet.

SPECIALIST STAFF

- If teaching should direct students as to the correct route out of the building.
- Should provide support in guiding students so their Assembly points.
- PE / Music Staff should assemble in designated area and provide additional support if requested

Year coordinator &

YEAR LEADERS

- Should fulfil all the requirements of a Class teacher.
- If a Form Tutor is absent, they should act in place of that staff member quickly
- Should (as possible) identify (through the Class/ Form Teachers) if all students are accounted for, and the identities of those not accounted for, before passing this information on to DHT

DEPUTY HEADTEACHERS

- Should sweep the allocated areas of the school, assuring no students / staff remain.
- As quickly as possible communicate with HOY/ YL at assembly points to identify if all students are accounted for.
- Pass on to Principal Inform on of students accounted and missing





SUPPORT STAFF

- Teaching assistants (Primary) should accompany classes to assembly points and assist class teachers
- Lab technicians should ensure that prep room and lab facilities are secure and left in a safe manner before assembling with Admin Staff
- Library Staff should act to support teaching staff.

ADMIN STAFF

- Secretaries should immediately collect registers not with Class / Form teachers and deliver them to the relevant assembly points
- Reception staff should collect visitors logs and assemble at the Visitor assembly point to ensure all visitors are accounted for.
- Assigned Reception staff should act as Primary Link and report to Relevant Deputy Headteachers
- Admin supervisor should coordinate with Principal regarding alarm and with reception staff on accounted visitors

NO ONE SHOULD REENTER THE BUILDING WITHOUT DIRECT INSTRUCTIONS FROM SLT

EEYR 2017



EMERGENCY B

R
E
P
O
R
T
I
N
G
S
T
R
U
C
T
U
R
E

PRINCIPAL

**EMERGENC
Y
SERVICES**

ADMIN SUPERVISOR

D

**E
P
U
T
Y
H
E
A
D
T
E
A
C
H
E
R**

VISITOR LINK

**YEAR LEADER / Year
coordinator**

**RECEPTION
– PRIMARY
LINK**



